

## Technical Data

MAXIMUM RECOMMENDED MOUNTING HEIGHT: 3.0m

RANGE: Cone-shaped detection pattern, diameter (at floor level) = 2.4 x mounting height

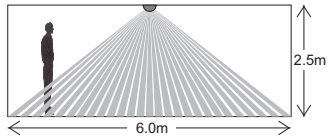

OPERATING VOLTAGE: 230V 50Hz (UK & Europe)

ta = 0 - 50°C

CAPACITY: **Total load must not exceed 2 AMPS, up to 4 Ballasts MAX**

**Electronic, high-frequency ballasts ONLY**

INTERCONNECT CABLE TEMPERATURE RATING: 60°C

COLOUR: White or silver bezel (DHW = White, DHS = Silver)

MATERIAL: UV stabilised polycarbonate (DHW/DHS)

Flame retardant PC/ABS (MSM2000A)

IP RATING: 20

DIMENSIONS: See diagrams overleaf

WEIGHT: 32g (DHW/DHS)

48g (MSM2000A)



## LightSpot Digital Luminaire Controllers

**MSM2000A - Control Module**

**DHW/DHS - Mini Detector Head**

for use with Analogue 1-10V and Fixed-Output

Electronic High-frequency Ballasts



## Installation and Commissioning Instructions

Note: HP2000 or HP10 required for commissioning

## Ex-Or

Haydock Lane, Haydock, Merseyside WA11 9UJ

Tel: +44 (0)1942 719229

Fax: +44 (0)1942 272767

Email: [technicalsales.ex-or@honeywell.com](mailto:technicalsales.ex-or@honeywell.com)

[www.ex-or.com](http://www.ex-or.com)



At the end of their useful life the packaging and product should be disposed of via a suitable recycling centre. Do not dispose of with normal household waste. Do not burn.



W4206G

## Electrical Connections

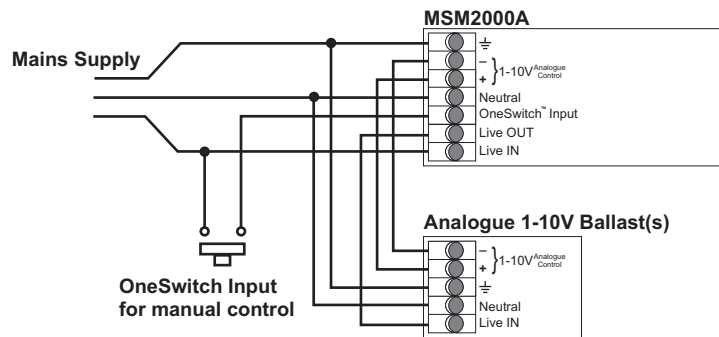
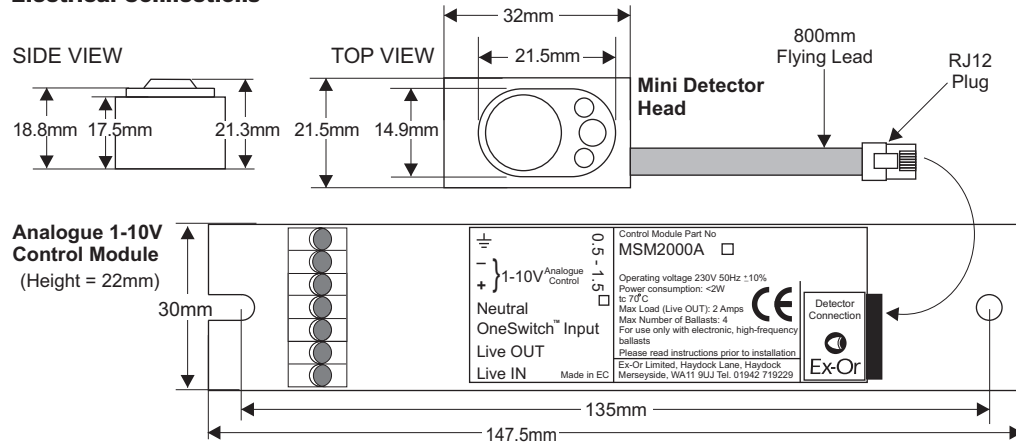

## Mounting Details

The MSM2000A Control Module is designed to be mounted within the luminaire on fixing centres of 135mm. Connections to the control module as shown above should be made using single-core wire (0.5-1.5mm<sup>2</sup>).

The interconnect cable between the detector head and control module should be routed away from the other luminaire internal wiring and away from the lamp end-caps.

The recommended position for the detector is in the middle of the luminaire. Where this is not possible and the sensor is fitted near one end of the lamps, please ensure that the sensor is at the "cold" end of the lamps.

The DHW/S Mini Head should be mounted such that only the raised front section of the bezel protrudes through the cut out in the louvre or infill panel. This should be constructed in accordance with the dimensions above.

## Installation Guidelines

1. The Mini Detector Head must be mounted within the luminaire. Do not mount remotely.
2. The connecting cable must not be extended.
3. Artificial light illuminating the Mini Head must only be reflected from the room - i.e. there must be no direct illumination.
4. In order to receive satisfactory light-level regulating operation, a detector must observe a substantially greater proportion of artificial light from the luminaire(s) under its control than from neighbouring luminaires not under its control. This is particularly important when planning the installed layout of linear luminaires that have an integral detector positioned at one end.
5. Please read Application Note AN4015 for general advice on how to optimise the installation of presence detectors intended for light-level regulation.

## Advanced Features

### Photocell

The MSM2000A incorporates a photocell which can be configured to operate in three different modes, selectable from within the product's menus on the HP2000 MLS Programmer. These modes are 'regulating', 'passive' and 'none' (only 'regulating' or 'passive' can be selected using the HP10). Note that in *any* mode of operation, the photocell affects the light output only when the Entry Scene is set to Scene 1.

### Setting the regulating photocell

This product is intended for use with high frequency regulating ballasts with analogue 1-10V control inputs. An infrared programming tool HP2000 or HP10 is required for programming the regulating light level set point. The setting is preserved in the event of a power failure and can be re-programmed any number of times.

The MSM2000A is set by default to operate in 'regulating' mode. Using the HP2000 MLS Programmer, enter the Utilities menu and select 'Set Light Level'. Use the 'up' and 'down' buttons to manually adjust the light output from the luminaire(s) and when at the required level press and hold 'OK' to store. The luminaire(s) will blink to acknowledge a successful store operation.

### Setting the passive photocell

It is recommended that this be set using the HP2000 as this provides feedback as to the perceived lighting level.

Use Passive mode in applications where light level regulation is not required (eg, when controlling non-dimmable ballasts) but it is desirable to hold off the controlled lighting when natural light is sufficient.

The parameter '**Threshold**' on the HP2000 menu is used to programme the MSM2000A's passive photocell set point, which determines whether the lights will be allowed to turn on as an unoccupied area is entered. The threshold is programmed as a number between 1 (darkest) and 254 (brightest). This number is not scaled to correlate with 'lux' measurements made using a light meter, but nevertheless is a true representation of the light level perceived by the MSM2000A.

In order to assist with selection of the appropriate threshold setting, the light level currently perceived by the detector (in terms of a number between 1 and 254) can be viewed on the HP2000 screen briefly following a download operation. The number represents the light level immediately before the download operation took place. *Tip: turn the lights off first using the **User Remote** menu found in **Utilities** if you want to measure the perceived ambient light level with no contribution from the controlled lighting.*

Note: When setting the regulating light level as described in the previous section, the Threshold is also set to the current measured level.

### OneSwitch™ Dimming

OneSwitch dimming affords local control to the end-user whereby a simple, momentary, push-to-make wallswitch can be used to raise or lower the lighting level or to toggle the output ON/OFF. A press of less than 1 second will toggle the output status while a longer press will raise or lower the output. Each time the switch is pressed, the direction of dimming reverses. If the switch has not been pressed for 5 seconds, the direction will be up (brighter) - unless the output is already above 90% (dc 8V) in which case the direction is down.

### Important Additional Notes

1. A means for disconnection must be incorporated in the fixed wiring in accordance with the current wiring regulations.
2. The dimming control output should be connected only to the control input of the ballasts - never to other detectors.
3. This equipment should be used to control only those ballasts powered from the same phase as the detector.
4. Due to the fact that the photocell is on the ceiling looking down, it is not possible for measurements made with a lux meter on the working plane to remain constant when daylight illuminates the ceiling and the working plane to a differing extent. Therefore, products of this type should be regarded as capable of maintaining an APPROXIMATE light level only.
5. This equipment switches lights no more frequently than would a responsible human occupant. However, manufacturers of some particular lighting types (e.g. '2D' luminaires) may specify a maximum number of switching cycles in order to achieve a predicted lamp life. Please check with the manufacturer of the luminaires to ensure that they are compatible with automatic controls in this respect.
6. Some devices in this product range feature a silvered surface finish; this is intended for decorative purposes only. Care should be taken to avoid accidental separation of the silvered coating from the product. If the unit is built into a luminaire that is subsequently wrapped in film having adhesive properties, it is recommended that a layer of suitable packaging material be used to protect the silvered area.