

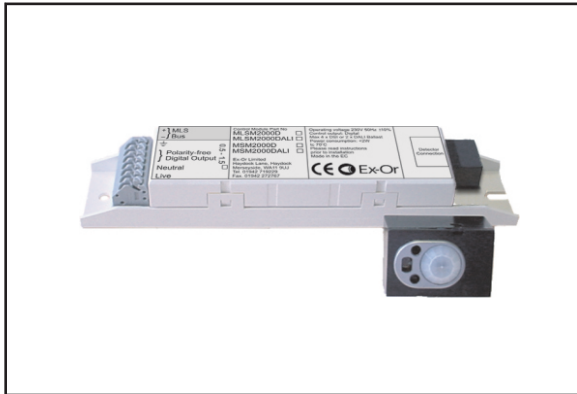

by Honeywell

LightSpot Luminaire Controllers
MSM2000D/DALI - Digital Control Module
DHW/DHS - Mini Detector Head



Installation and Commissioning
Instructions

Note: HP2000 (or HP10*/HP18*) required for commissioning
* Please note that the HP10 and HP18 offer different/limited programming options

Electrical Connections

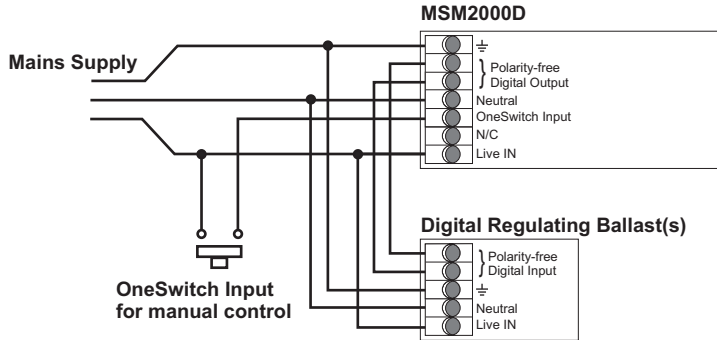
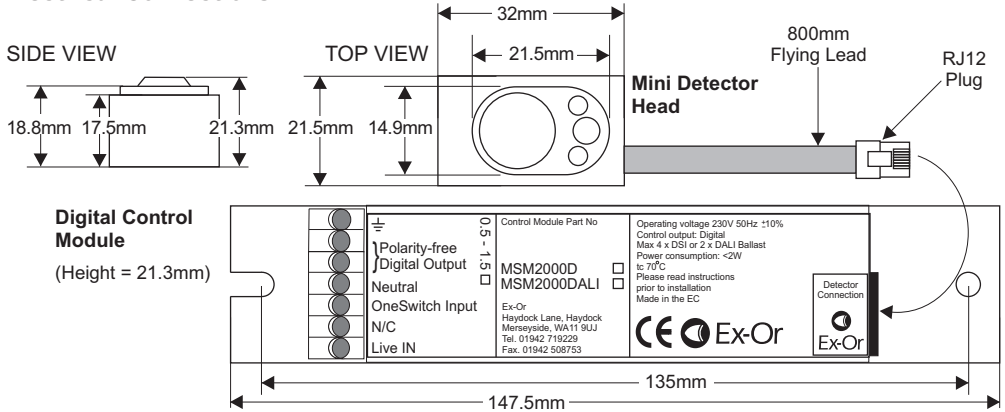

Mounting Details

The MSM2000 Control Module is designed to be mounted within the luminaire on fixing centres of 135mm. Connections to the control module as shown above should be made using solid strand wire (0.5-1.5mm²).

The interconnect cable between the detector head and control module should be routed away from other luminaire internal wiring and away from the lamp end-caps.

The recommended position for the detector is in the middle of the luminaire. Where this is not possible and the detector is fitted near on end of the lamps, please ensure that the detector is at the 'cold' end of the lamps.

The DHW/S Mini Detector Head should be mounted such that only the raised front section of the bezel protrudes through the cut out in the louvre or infill panel, constructed in accordance with the dimensions above.

Installation Guidelines

1. The Mini Detector Head must be mounted within the luminaire. Do not mount remotely.
2. The connecting cable must not be extended.
3. Artificial light illuminating the Mini Detector Head must only be reflected from the room - i.e. there must be no direct illumination.
4. In order to receive satisfactory light-level regulating operation, a detector must observe a substantially greater proportion of artificial light from the luminaire(s) under its control than from neighbouring luminaires not under its control. This is particularly important when planning the installed layout of linear luminaires that have an integral detector positioned at one end.

Commissioning

Detectors are supplied factory pre-set which ensures the lighting will switch on automatically as soon as power is applied. Final commissioning of the detectors requires the use of an infrared Programmer. The HP2000 gives access to the full range of parameters and options but limited programming functions can also be carried out using an HP10 or HP18.

Commissioning Detectors using the HP2000

Please refer to HP2000 instructions for comprehensive commissioning instructions.

1. Switch on HP2000 by pressing the red power button.
2. Point HP2000 at detector and press the DOWNLOAD button. The HP2000 will confirm the product's identity and call up the correct menu of parameters and their current settings.
3. Use a combination of UP, DOWN, FORWARD and BACK buttons to navigate the parameter menu, selecting options for each shown. (See Tips below.)
4. When options for all parameters have been selected, point the HP2000 at the detector and press the UPLOAD button. The luminaire(s) will switch off briefly during the programming process and the HP2000 shows DATA OK to confirm operation.
5. After a short period of inactivity (default 5 minutes), the HP2000 hibernates retaining the most recent settings.

Tips

- i) Where there are only two options such as ON/OFF, a double click of the OK button toggles between them.
- ii) Where there are multiple options, a double click of the OK button recalls a list of all options for that parameter. Use the UP, DOWN and OK buttons to select.
- iii) Use the OK button to go forward (through the menus) without displaying help pages.
- iv) Press UPLOAD at any time to transfer all current settings from the handset to the product.

OneSwitch Dimming

OneSwitch dimming affords local control to the end-user whereby a simple, momentary, push-to-make wall switch can be used to raise or lower the lighting level or to toggle the output ON/OFF. A press of less than 1 second will toggle the output status while a longer press will raise or lower the output. Each time the switch is pressed, the direction of dimming reverses. If the switch has not been pressed for 5 seconds, the direction will be up (brighter) - unless the output is already above 90% (dc 8V) in which case the direction is down.

To Test with Hand-held Controller

Once the LightSpot Luminaire Controllers have been installed within the luminaires, a Hand-held Controller or Programmer (HC5, HC6 or HP18) may be used to dim and brighten luminaires and to switch them ON and OFF.

NB: See also 'Important Additional Notes' overleaf.

Technical Data

MAXIMUM RECOMMENDED MOUNTING HEIGHT: 3.0m

RANGE: Cone-shaped detection pattern, diameter (at floor level) = 2.4 x mounting height

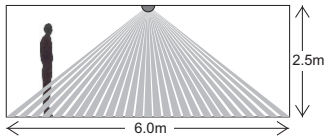

OPERATING VOLTAGE: 230V 50Hz (UK & Europe)

ta = 0 - 50°C

CAPACITY: 4 ballasts max (DSI Digital)

2 ballast max (DALI)

INTERCONNECT CABLE TEMPERATURE RATING: 60°C

COLOUR: White or silver bezel (DHW = White, DHS = Silver)

MATERIAL: UV stabilised polycarbonate (DHW/DHS)

Flame retardant PC/ABS (MSM2000D/DALI)

IP RATING: 20

DIMENSIONS: 32 (l) x 21 (w) x 18.6 (h) mm (DHW/DHS)

147 (l) x 30 (w) x 21 (h) mm (MSM2000D/DALI)

WEIGHT: 32g (DHW/DHS)

48g (MSM2000D/DALI)

Important Additional Notes

1. A means for disconnection must be incorporated in the fixed wiring in accordance with the current wiring regulations.
2. Although nominally 12V, the dimming output is not SELV and therefore should be treated with the same respect as mains with regard to wiring practice. The 0V line of the dimming output is almost at Neutral potential.
3. The dimming control output should be connected only to the control input of the ballasts - never to other detectors.
4. This equipment should be used to control only those ballasts powered from the same phase as the detector.
5. Due to the fact that the photocell is on the ceiling looking down, it is not possible for measurements made with a lux meter on the working plane to remain constant when daylight illuminates the ceiling and the working plane to a differing extent. Therefore, products of this type should be regarded as capable of maintaining an APPROXIMATE light level only.
6. This equipment switches lights no more frequently than would a responsible human occupant. However, manufacturers of some particular lighting types (e.g. '2D' luminaires) may specify a maximum number of switching cycles in order to achieve a predicted lamp life. Please check with the manufacturer of the luminaires to ensure that they are compatible with automatic controls in this respect.
7. Some devices in this product range feature a silvered surface finish; this is intended for decorative purposes only. Care should be taken to avoid accidental separation of the silvered coating from the product. If the unit is built into a luminaire that is subsequently wrapped in film having adhesive properties, it is recommended that a layer of suitable packaging material be used to protect the silvered area.

Ex-Or

Novar ED&S Limited
Haydock Lane, Haydock, Merseyside WA11 9UJ

Tel: +44 (0)1942 719229

Fax: +44 (0)1942 508753

Email: technicalsales.ex-or@com

www.ex-or.com



At the end of their useful life the packaging and product should be disposed of via a suitable recycling centre. Do not dispose of with normal household waste. Do not burn.



W4267E