

MLS Digital - Networked Managed Lighting System

RB2000 MLS Digital Bus Power Supply

A single RB2000 Bus Power Supply powers and synchronises the bus for up to 200 MLS Digital devices. It is equipped with a test facility which provides a simple check of the bus integrity and five override inputs to enable easy control of complete systems from one centralised location.

Linking of the Bus Power Supply units enables a building-wide common zone to be established without the need for additional hardware. Up to 99 RB2000 Bus Power Supply units can be connected together (per installation) increasing capacity to almost 20,000 devices on a single MLS Digital system.



Wiring the MLS Network

The MLS Digital bus network consists of a 1.5mm² mains-rated, unscreened twisted pair which connects every MLS Digital device (MLS Detectors and Transceivers) before returning to the bus power supply. Up to 200 devices can be connected to one RB2000. See Application Note AN4001 - MLS Bus Wiring for further details.

Wiring Topology

The MLS Digital bus may be wired in any combination of spurs or rings. It is recommended however that a ring topology is used so that its integrity can be checked. It should be wired from the 'OUT' terminals to every device on the system, coming back to the 'RETURN' terminals. The polarity of the bus must always be maintained.

Installation & Connection

The RB2000 Bus Power Supply should be positioned in a readily accessible location, usually adjacent to the mains distribution board for the area being controlled. A fused 3A, 230 volt mains supply is required which should be dedicated to the RB2000 for maximum reliability.

Example Wiring of System

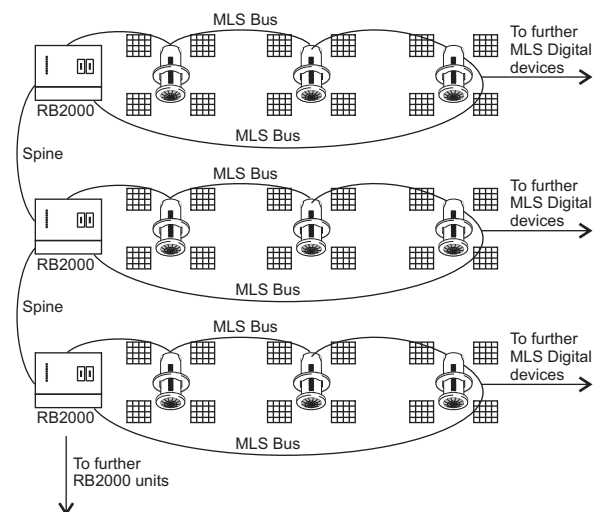

Connecting Multiple RB2000s

On larger installations where multiple RB2000 units are required, they may be connected together via a 'spine' or 'backbone'. The spine should be wired using 24AWG two twisted pair, screened communications cable, e.g. Belden 9502. When RB2000s are linked in this way Common Zone 1 becomes a 'Building Zone', providing building-wide Common Zone 1 linking.

Please check www.ex-or.com to ensure this is the most recent issue - Ref: D4051J

Internal Connections

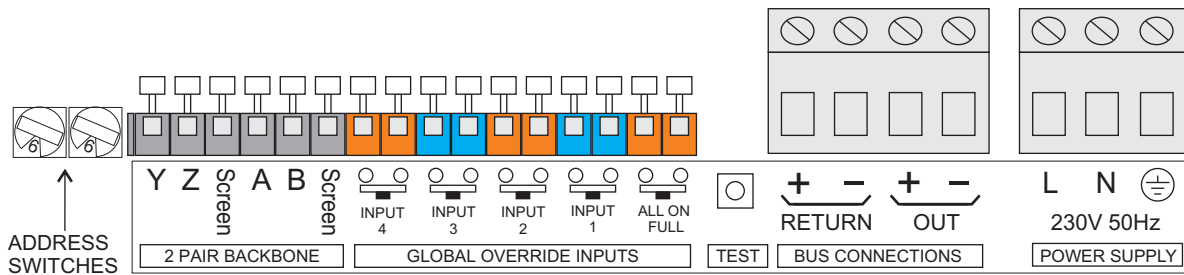

Override Inputs

Five pairs of switch input terminals located behind the lower housing cover enable easy control of complete systems from one centralised location. Inputs require a latching, normally-open switch or a momentary, push-to-make switch as appropriate, their default operation is detailed below:-

All On Full

This command affects every device on the MLS Bus

When the switch is made, all devices turn on at the highest level of brightness allowed by the detectors (Lamp Max). When released, the devices go to their Entry Scene for at least one Off Delay period. (This function is also available via a keyswitch on the front panel.)

INPUT 1 - Emergency Test

This command affects only CDW10U5, CDW12U5, CDH4U5 & CDH8U5 Connection Centres and the MLS2000ETM Emergency Test Module

When the switch is made, the CD Box will drop out its connection between the Maintained Live input to the box and the Maintained Live outputs at the luminaire sockets. This function times out after 3 hours.

INPUT 2 - Load Shed 2

This command is addressed to each device on the MLS Bus that has been programmed to 'Global Address 2 Rx: YES'

When the switch is made, all relevant devices turn off.

Note: After the Load Shed (1 or 2) switch is released, the detectors will either remain off if the area is vacant or turn on (at their Entry Scene) as soon as occupancy is detected.

INPUT 3 - Load Shed 1

This command is addressed to each device on the MLS Bus that has been programmed to 'Global Address 1 Rx: YES'

When the switch is made, all relevant devices turn off.

INPUT 4 - Reset CD Boxes

This command affects only CDW10U5 Connection Centres with wall switch overrides connected.

When activated it will cause all wall switch operated lights to switch off, even if the switch is in the on position. It can be used, for example, to turn lights off that may have been left on accidentally (via a wall switch) anywhere on the system. However, if presence detectors are installed, they will continue to hold the lights on if the area is occupied. Note: the original function of a wall switch may be restored at any time simply by toggling it.

Front Panel

The status of each switch at any given time is indicated through five green LEDs located on the front panel of the RB2000. They illuminate only when the switch associated with each command is closed. The LEDs go out instantly when the switch is opened although the actual command may still be active on the bus for up to 30 seconds.

The 'All On Full' command can be instigated via a keyswitch on the front panel.

The red Power LED will illuminate when mains power is applied to the unit.

The colourless Activity LED flashes green only when there is activity in any zone on the bus. (Note: detectors that have not been programmed with a zone will not cause this LED to flash.) It flashes red when a bus installation fault is detected regardless of movement or occupancy in the building. Please note that not all faults will be indicated by this LED.

The yellow Linking LED will flash when multiple RB2000s are connected together and Common Zone 1 linking occurs.

Technical Data

Operating voltage: 230V ~ 50Hz (UK & Europe)

Power consumption: <10W

Maximum number of linked RB2000 units per installation: 99

Maximum number of devices per RB2000: 200

Maximum total length of MLS bus cable (ring topology): 1500m

Dimensions (w x d x h): 213 x 185 x 117mm

IP rating: 65

Cable Specifications

MLS Digital Bus cable: 1.5mm² unscreened twisted-pair from UK Cables (0161 653 6789), Part number 'SensaLink MLS'. Available in 440V or 600V rating.

Spine/Backbone cable: Belden 9502, available from RS 382-7303 (304m)

Override cable: Any mains-rated cable, e.g. 0.5mm² two-core.

Ex-Or operates a genuine policy of continuous improvement. You may expect the specification to be regularly enhanced. For latest technical information, please visit www.ex-or.com.