

LightSpot - Stand-alone precision lighting control by presence detection and photocell

Mid-Bay LightSpot (Regulating)

- Mid-Bay LightSpot offers energy-saving PIR presence detection at heights of up to 12m.
- Idea for warehouses and industrial units.
- 1 : 1.75 Coverage ratio for optimum precision detection, i.e. 8m mounting height results in a detector footprint of 14m diameter circle.
- Set and adjust the PIR detector to your requirements.
- Easy programming from ground level via infrared programmer.
- Lens mask available for end-of-aisle applications.
- Versions for DSI, DALI and 1-10V Analogue ballasts are available.



Presence detection is by passive infrared, effectively enhanced to improve sensitivity to small movements.



Regulating photocell ensures a minimum maintained light level, taking account of the contribution from adjacent luminaires and daylight (dimmable control gear only).



Passive photocell holds lights off in bright conditions. Active photocell has the capability to switch lights off in occupied areas. (Options with Analogue version only.)



Off delay: Period following the last observed movement after which the lights switch off, adjustable via HP2000. (Also 5, 10 or 20 mins via HP18).



Detection pattern and range in metres at floor level (detection pattern is cone shaped). Range to mounting height ratio is 1:1.75, i.e. at 8m height, the cone's diameter is 14m at the floor.



Incorporates simple scene-setting - up to six scenes can be set or recalled via user remote.



Remote programming via HP2000 (or HP18 with limited choice of parameters) ensures changes can be easily accommodated.



OneSwitch Dimming. Manual input to adjust light level or turn luminaires on or off.



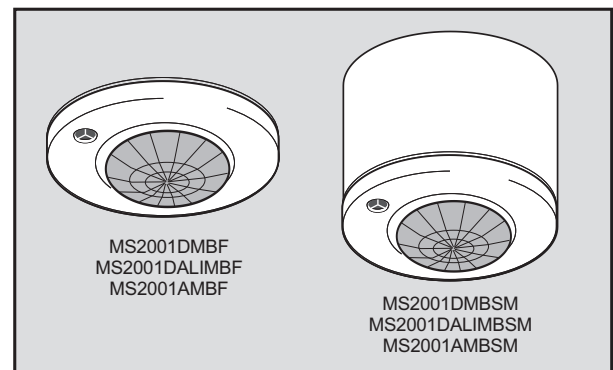

100-hour Burn-in. Inhibits dimming functions to allow new lamps to burn in. (Available on DSI and DALI version detectors and via HP2000 only.)

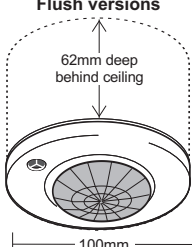
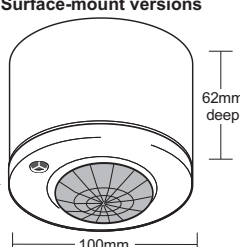
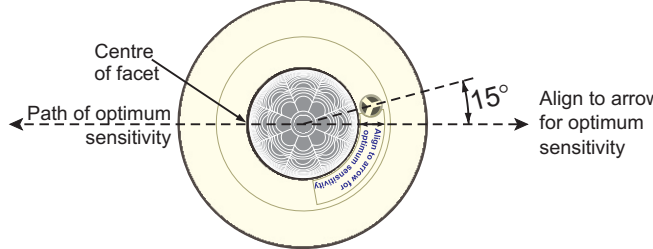
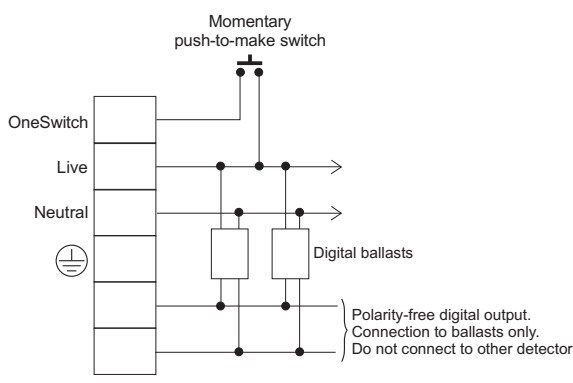
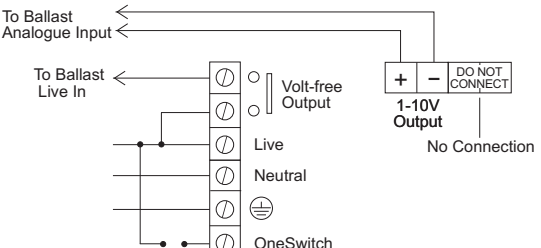
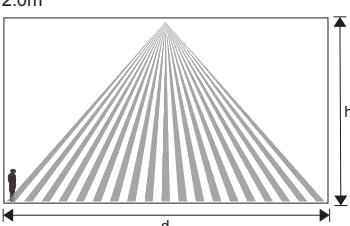

Programmable Parameters	
POWER UP	Options: On/Off
Sets the status of luminaires when power is applied. On - lights power-up on irrespective of occupancy. Off - lights respond to occupancy after 30 seconds.	
RESPONSE	Options: Auto/Semi-auto
Auto - lights switch on and off automatically. Semi-auto - lights are switched on by wall switch or hand-held controller and switch off automatically.	
OFF DELAY	Options: 1 minute - 96 hours
Sets the period after the last observed movement when the lights switch off. (In walk-test mode, Off Delay is 10 secs.)	
ON SENSITIVITY (DSI/DALI Versions)	Options: 0-100
Sensitivity to movement when area is occupied.	
START LAMPS	Options: Max/Min
Sets the level at which lamps strike when turning on.	
ENTRY SCENE	Options: Scenes 1-6
Sets which scene is recalled on entering unoccupied area.	
BRIGHT OUT	Options: Yes/No
Movement will not refresh the off delay if ambient light exceeds 125% of set level.	
DIMMING (DSI/DALI Versions)	Options: 50-100%
Can be set to operate between 50% and 100% ballast output from max to a bottom end limit when working on photocell control.	
PHOTOCELL (Analogue Versions)	Options: 50-100%, Passive, Active, Disabled
Sets the regulating range of the ballast in daylight conditions. Manual override is not affected.	
LAMP MAX	Options: 10-100%
Limits the absolute maximum ballast output.	
FADE TO OFF	Options: Yes/No
Can set lamps to fade to off instead of switching off.	
WHEN VACANT	Options: Off/Min/Reg<25%/Scene 6
Determines behaviour of luminaires once the Off Delay has expired. Luminaires can switch off or go to a pre-determined level for a chosen duration: There are 3 light output options and 3 time choice. Note that 'Go to Scene 6' is available on analogue versions only.	
LOWER/UPPER THRESHOLD (Analogue Versions)	Options: 0-254
Point at which photocell switches luminaires on/off.	
SET-POINT LOW/HIGH (DSI/DALI Versions)	Options: 0-1023
Low - aiming point as photocell adjusts ballast output. High - level above which photocell switches its output off (only if Bright-out = Yes)	
100-HR BURN-IN (DSI/DALI Versions)	Options: Burn-in/Cancel/Resume
Inhibits dimming functions - see Application Note AN4028	

Please check www.ex-or.com to ensure this is the most recent issue - Ref: D4132C

Dimensions and Installation Notes	Example Wiring Diagram	
<div style="display: flex; justify-content: space-around;"> <div style="text-align: center;"> <p>Flush versions</p>  </div> <div style="text-align: center;"> <p>Surface-mount versions</p>  </div> </div> <p>Flush versions: Depth required behind ceiling: 62mm from front flange plus allowance for the minimum bend radius of the cable. Sinking box fits into 89mm diameter hole in ceiling tile or plasterboard ceiling. Note: If the sinking box is being fitted to a hard substrate such as metal, increase the hole size to 91mm. No access above the ceiling is necessary. The detector fits into sinking box with a simple bayonet action thus concealing the fixing screws.</p> <p>Surface versions: The housing may be secured to a hard surface or a BESA box. The detector fits into the housing with a simple bayonet action.</p> <p>Note: Minimum mounting pitch (spacing) when in regulating mode = 0.5 x mounting height.</p> <p>For aisle or corridor applications, there is an optimum orientation for approach, clearly indicated on the front of the product.</p> <div style="text-align: center;">  <p>Align to arrow for optimum sensitivity</p> </div>	<p>DSI/DALI Versions</p>  <p>Momentary push-to-make switch</p> <p>OneSwitch</p> <p>Live</p> <p>Neutral</p> <p>Digital ballasts</p> <p>Polarity-free digital output. Connection to ballasts only. Do not connect to other detectors.</p> <hr/> <p>Analogue Versions</p>  <p>To Ballast Analogue Input</p> <p>To Ballast Live In</p> <p>Volt-free Output</p> <p>Live</p> <p>Neutral</p> <p>OneSwitch</p> <p>1-10V Output</p> <p>DO NOT CONNECT</p> <p>No Connection</p> <p>Note: If more than one detector is used in an area, the detectors' 1-10V outputs must not be linked.</p>	
Technical Data		
<p>MAX RECOMMENDED MOUNTING HEIGHT: 12.0m</p> <p>RANGE: 360° cone-shaped detection pattern, diameter (at floor level) = 1.75 x mounting height</p>  <p>TERMINAL CAPACITY: 2 x 2.5mm²</p> <p>MINIMUM MOUNTING PITCH (SPACING): 0.5 x mounting height (when in regulating mode)</p> <p>PRODUCT RATING & RECOMMENDED CIRCUIT PROTECTION: 10 Amps</p> <p>OFF DELAY: Adjustable: 1 minute - 96 hours via HP2000; 5, 10 or 20 min via HP18 - plus 10 second Walk-test Mode</p> <p>DEPTH REQUIRED BEHIND CEILING (FLUSH VERSION): 62mm from front flange plus an allowance for the minimum bend radius of the cables.</p> <p>COLOUR: White</p> <p>MATERIAL: Flame retardant PC/ABS</p> <p>WEIGHT: 200g approx</p> <p>OPERATING TEMPERATURE: 0°C to 40°C</p>	<p>Analogue Versions</p> <p>CAPACITY: 6 Amps (25 ballasts max)</p> <p>OUTPUT: 1-10V Analogue</p> <p>IP RATING: 3X</p> <p>PHOTOCELL: Regulating/Active/Passive</p> <p>DSI/DALI Versions</p> <p>CAPACITY: 25 ballasts</p> <p>OUTPUT: 2-wire digital polarity free</p> <p>IP RATING: 4X</p> <p>PHOTOCELL: Regulating</p>	
Ancillary Items		
 <p>HP2000 MLS Digital Programmer</p> <p>Menu-driven LCD Programmer with automatic equipment recognition and parameter download facilities.</p>	 <p>HP18 LightSpot Programmer</p> <p>User-friendly override/programming remote controller. Note: The HP18 does not give access to the full range of parameters.</p>	<p>MBPIRLM</p> <p>Lens mask to prevent end-of-aisle movement from being detected.</p>

Ex-Or operates a genuine policy of continuous improvement. You may expect the specification to be regularly enhanced. For latest technical information, please visit www.ex-or.com

Part Numbers

MS2001DMBF	Mid-Bay LightSpot for DSI ballasts - flush
MS2001DMBSM	Mid-Bay LightSpot for DSI ballasts - surface
MS2001DALIMBF	Mid-Bay LightSpot for DALI ballasts - flush
MS2001DALIMBSM	Mid-Bay LightSpot for DALI ballasts - surface
MS2001AMBF	Mid Bay LightSpot for 1-10V Analogue ballasts - flush
MS2001AMBSM	Mid Bay LightSpot for 1-10V Analogue ballasts - surface
HP2000	MLS Digital Programmer
HP18	LightSpot Programmer
MBPIRLM	Lens Mask