

RB2000 - MLS Digital Bus Power Supply

This latest generation MLS Bus Power Supply is for use only with Ex-Or's MLS Digital range of presence detectors and accessories. Up to 99 RB2000s can be connected together (per installation) increasing capacity to almost 20,000 devices on a single MLS Digital system.

Installation & Connection

The RB2000 Bus Power Supply should be positioned in a readily accessible location, usually adjacent to the mains distribution board for the area being controlled. A fused 3A, 230 volt mains supply is required which should be dedicated to the RB2000 for maximum reliability. This device **MUST** be earthed. It is recommended that Double-pole Isolation is provided.

The MLS Digital bus network should be wired using 1.5mm mains-rated, unscreened twisted pair, which starts from the bus power supply and connects into every MLS Digital device. Up to 200 devices can be connected to one RB2000. **DO NOT CONNECT MAINS TO THE MLS BUS.**

This equipment should be installed only by suitably qualified personnel.

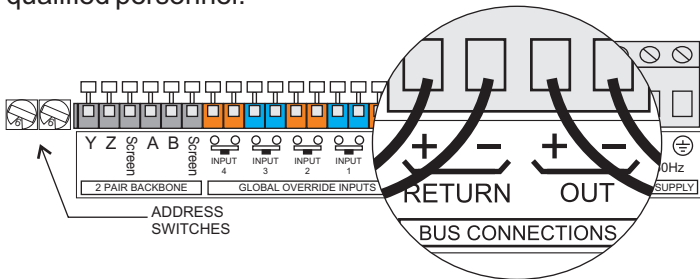

Wiring Topology

The MLS Digital Bus may be wired in a 'free topology' - i.e. any combination of spurs and rings. It is recommended however, that a ring topology is used so that the integrity can be checked. It should be wired from the 'OUT' terminals to every device on the system, coming back to the 'RETURN' terminals. The polarity of the MLS Digital Bus must always be maintained. The switch to the left of the bus terminal blocks, when pressed, performs an integrity check on the bus. A correctly installed ring system will cause the green LED below the switch to flicker. See Application Note AN4001 - **MLS Bus Wiring** for further details.

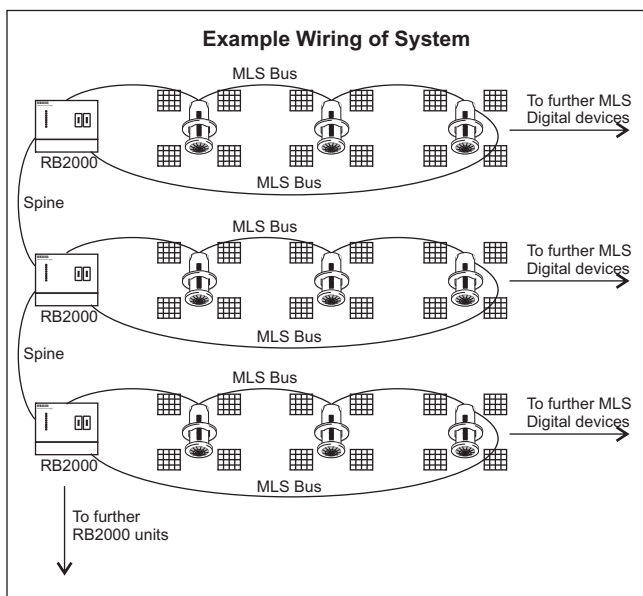

Connecting Multiple RB2000s

On larger installations where multiple RB2000 units are required, they may be connected together via a 'spine' or 'backbone'. The spine should be wired using 24AWG twin twisted pair, screened communications cable, e.g. Belden 9502. When RB2000s are linked in this way Common Zone 1 becomes a 'Building Zone', providing building-wide Common Zone 1 linking. The maximum length of the spine should not exceed 1200m with all RB2000s being linked in a single spur.

The spine should be linked to AB and YZ as shown (i). Note that the screen is not shown, however, it must be connected at each RB2000.

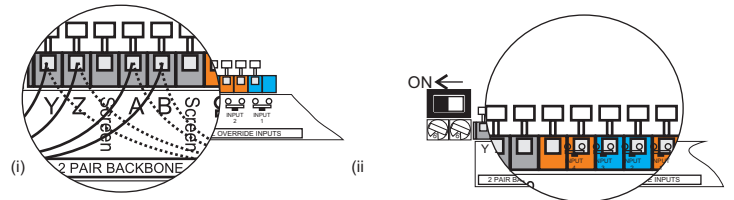

The RB2000 at each end of the line should have its Terminate switch set to ON as shown in figure (ii). All others should be set to OFF.

Notes

For the installation to work correctly:

- Every device must be connected
- The polarity must be maintained
- There should be no more than 200 devices per RB2000 Bus Power Supply

Devices on the bus may be connected in any order. Spurs are permissible but are best avoided as they will not be checked during the integrity test. Accurate as-fitted records will assist in fault finding. The bus may be run with mains wiring providing twisted pair bus cable as detailed above is used throughout.

Set the address switches of each RB2000 on the system to any unique number from '00' to '99'. One unit must be set to address '00' to act as 'master'.

Override Inputs

Five pairs of switch input terminals located behind the lower housing cover enable easy control of complete systems from one centralised location. Inputs require a latching, normally-open switch or a momentary, push-to-make switch as appropriate. The functions outlined below are system defaults and may not be applicable to all projects:-

All On Full - This command affects every device on the MLS Bus.

Use a latching normally-open switch. When the switch is made, all devices turn on at the highest level of brightness allowed by the detectors (Lamp Max). The devices will go to their 'Entry Scene' no later than 30 seconds after the switch is released. Please note this function is also available via a keyswitch on the front panel.

Override Inputs - continued

INPUT 1 - 'Emergency Test' - This command affects only CDW10U5, CDW12U5, CDH4U5 & CDH8U5 Connection Centres and MLS2000ETM.

Use a latching normally-open switch. When the switch is made, the CD Box will drop out its connection between the Maintained Live input to the box and the Maintained Live outputs at the luminaire sockets. The connection will be restored no later than 30 seconds after the switch is released. This function times out after 3 hours.

INPUT 2 - 'Load Shed 2' - This command is addressed to each device on the MLS Bus that has been programmed to 'GlobalAddress 2 Rx: YES'.

Use a latching normally-open switch. When the switch is made, all relevant devices turn off. The devices will begin responding the movement again (go to their 'Entry Scene' if the area is occupied) no later than 30 seconds after the switch is released.

INPUT 3 - 'Load Shed 1' - This command is addressed to each device on the MLS Bus that has been programmed to 'GlobalAddress 1 Rx: YES'.

Use a latching normally-open switch. When the switch is made, all relevant devices turn off. The devices will begin responding the movement again (go to their 'Entry Scene' if the area is occupied) no later than 30 seconds after the switch is released.

INPUT 4, 'Reset CD Boxes' - This command affects only the CDW10U5 Connection Centres.

Use a momentary push-to-make switch. When pressed it will cause any wall switches connected to the CD Box to be considered open **even if they are actually closed** - used, for example, to turn lights off that may have been left on accidentally (via a wall switch) anywhere on the system. This condition will continue for each switch until it changes state - then the 'Reset' for **that switch only** is over.

Front Panel

The status of each switch at any given time is indicated through five green LEDs located on the front panel of the RB2000. They illuminate only when the switch associated with each command is closed. The LEDs go out instantly when the switch is opened although the actual command may still be active on the bus for up to 30 seconds.

The 'All On Full' command can be instigated via the keyswitch next to the LED array. A 'Bus Test' facility is also available. This test is carried out by operating the red momentary switch which will cause all devices on the MLS bus to turn on. A further operation (within 5 seconds of the initial operation) will turn all devices off.

The red Power LED will illuminate when mains power is applied to the unit.

The colourless Activity LED flashes green only when there is activity in any zone on the bus. It flashes red when a bus installation fault is detected regardless of movement or occupancy in the building. Please note that not all faults will be indicated by this LED.

The yellow Linking LED will flash when multiple RB2000s are connected together and Common Zone 1 linking occurs.

Technical Data

Operating voltage: 230V ~ 50Hz (UK & Europe)

Power consumption: <10W

Maximum number of linked
RB2000 units per installation: 99

Maximum number of devices per RB2000: 200

Maximum total length of
Bus cable (ring topology): 1500m

Dimensions (w x d x h): 213 x 185 x 117mm

IP rating: 65

Cable Specifications

MLS Digital Bus cable: 1.5mm² **unscreened** twisted-pair from UK Cables (0161 653 6789), Part number 'SensaLink MLS'. Available in 440V or 600V rating.

Spine/Backbone cable: Belden 9502, available from RS 382-7303 (304m)

Override cable: Any mains-rated cable, e.g. 0.5mm² two-core.

Ex-Or

Novar ED&S Limited
Haydock Lane, Haydock,
Merseyside WA11 9UJ
Tel: +44 (0)1942 719229
Fax: +44 (0)1942 508753
Email: technicalsales.ex-or@honeywell.com
www.ex-or.com

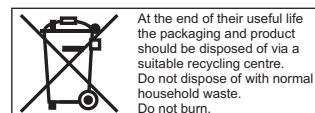

W4133J



by Honeywell

**RB2000
MLS Digital
Bus Power Supply**



**Installation and Commissioning
Instructions**