

Technical Data

MAXIMUM RECOMMENDED MOUNTING HEIGHT: 3 metres

RANGE: Cone-shaped detection pattern, diameter (at floor level) = 2.4 x mounting height

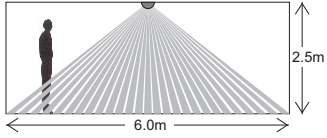

OPERATING VOLTAGE: 230V 50Hz (UK & Europe)

RECOMMENDED CIRCUIT PROTECTION: 10 Amps

MAXIMUM LOAD: 6 Amps resistive or fluorescent

PHOTOCELL: Adjustable 50-5000 lux via HP10 / HP2000

OFF DELAY: 20 minutes (fixed) and a 10-second Walk Test Mode

DEPTH REQUIRED BEHIND CEILING: 125mm

WEIGHT: 70g approx excluding cable

COLOUR: White

MATERIAL: Flame retardant PC/ABS

IP RATING: 4X



MS1100PF Slimline Bronze Series LightSpot with photocell

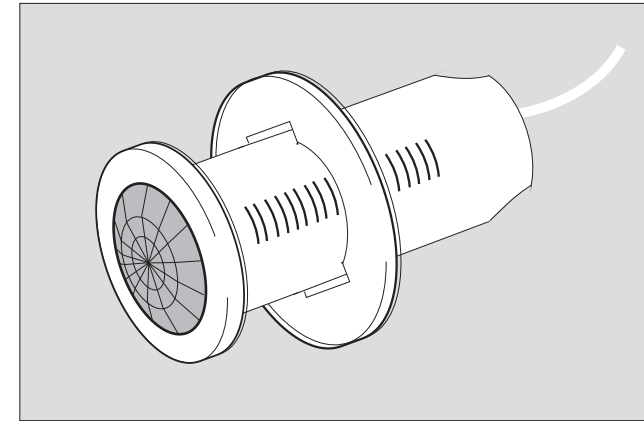

Installation and Commissioning Instructions

Note: HP2000 (or HP10) required for photocell commissioning
User override available via HC5 or HC6 Hand-held Controllers

Ex-Or

Haydock Lane, Haydock, Merseyside WA11 9UJ

Tel: +44 (0)1942 719229

Fax: +44 (0)1942 272767

Email: technicalsales.ex-or@honeywell.com

www.ex-or.com

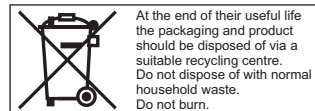

At the end of their useful life the packaging and product should be disposed of via a suitable recycling centre. Do not dispose of with normal household waste. Do not burn.



W4227G

Bronze Series LightSpot with photocell - MS1100PF

Only suitably qualified personnel should install this equipment.

This is a high-performance presence detector with photocell. The photocell can be programmed to hold lights off when areas become occupied if the daylight contribution is sufficient. It can also switch lights on in occupied areas as daylight falls (Passive mode).

Fixing

The detector is suitable for flush mounting in a suspended ceiling tile, maximum 54mm thick and with a minimum clearance of 125mm between the front surface of the tile and the hard ceiling behind. The detector should be mounted in the centre of the group of luminaires to be controlled. Cut a 50mm diameter (64mm if using an FR64 flush ring or PB64 plasterboard fixing kit) circular hole in the tile, feed the flying lead and detector through the hole and secure into position with the locking ring. Twisting the locking ring will release the detector should this be necessary.

Note: Do not mount within 25cm of a luminaire.

Electrical Connections

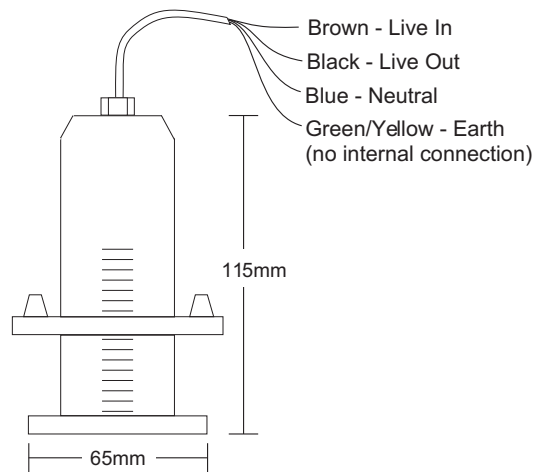

Important Additional Notes

1. Only suitably qualified personnel should install this equipment.
2. A means for disconnection must be incorporated in the fixed wiring in accordance with the current wiring regulations.
3. This equipment switches lights no more frequently than would a responsible human occupant. However, manufacturers of some lighting types (e.g. '2D' luminaires) may specify a maximum number of switching cycles in order to achieve a predicted lamp life. Please check with the manufacturer of the luminaires to ensure that they are compatible with automatic controls in this respect.

Commissioning

The units are supplied with factory default settings (power-up on, fully automatic operation, a 20 minute off delay, photocell disabled). Programme the photocell using the MLS Digital Programmer with LCD display (HP2000), or the LightSpot Programmer (HP10).

Off Delay

The Off Delay is set to 20 minutes and is non-adjustable. A 10-second Off Delay is available for walk testing the product.

Walk-test Mode

Walk-test mode is used to check that the detector is operating as required. The short off-delay enables the installer to check that lights are switching on when movements are made at the edge of the detection zone. It is easier to carry out a walk-test when the photocell is not holding the lights off.

1. Change the programmed Off Delay to 10 seconds using either an HP10 or HP2000. When using the HP10, just press the white button - switch positions are not recognised for this product. When using the HP2000, select Utilities from the main menu, then select Walk Test and press OK.
2. Move around the area that is being controlled, stopping for 10 seconds to allow the lights to switch off, before moving and triggering the lights back on. The Off Delay will reset to its 20 minutes after a five minute period.

Photocell Operation (Passive/Disabled)

The detector has an in-built photocell. The photocell has two modes of operation - Passive and Disabled. Its operational behaviour is governed by the setting chosen and by the value stored in the threshold.

Passive - The photocell will inhibit turn-on of the controlled load if sufficient natural light is available. It will not turn the load off whilst an area is occupied

Disabled - The photocell has no effect regardless of natural light levels.

Setting the Photocell

1. Wait until the time of day when the ambient light level is equal to the level at which you want the photocell to turn on the lights.
2. Using the HP2000, select 'Set Light Level' from the Utilities menu and press OK while pointing at the detector to store the current light level. The detector stores the value in the Threshold Parameter. This procedure can also be accomplished by using the HP10 Basic Programmer's 'Store' button, however editing of the stored threshold value is not possible with the HP10.
3. A numerical value (0-254) is stored in the Threshold parameter (viewable with an HP2000) and can be edited if necessary. A lower value indicates that the area must become progressively darker before the controlled lighting will switch ON.