

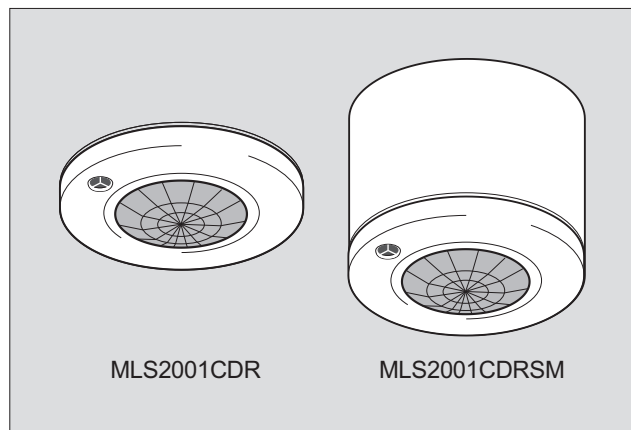

**MLS2001CDR and MLS2001CDRSM
360° Passive Infrared Detector with Photocell
for use with CDW12U5, CDH4U5 & CDH8U5
Programmable Intelligent Lighting Control Modules**



**Installation and Commissioning
Instructions**

(HC5 or HP2000 required for Photocell Commissioning)

Introduction

The MLS2001CDR offers high performance presence detection and contains a photocell to monitor total light levels, allowing the light output of dimmable luminaires to be adjusted to suit the natural light level available. It also contains an infrared port that can be used both for local control from a hand-held device, when in service, and for initial CDW12U5/CDH4U5/CDH8U5 system commissioning. When properly installed and connected the MLS2001CDR is an SELV device.

Fixing

The MLS2001CDR Flush Mounted Version - Depth required behind ceiling: 62mm from front flange plus an allowance for the minimum bend radius of the cable. Sinking box fits into a 89mm diameter hole in ceiling tile or plasterboard ceiling. To avoid damage to ceiling tile, do not overtighten. No access above the ceiling is necessary. The unit fits into the housing with a simple bayonet action.

The MLS2001CDRSM Surface Mounted Version - The housing may be secured to a hard surface or a BESA box. The unit fits into the housing with a simple bayonet action.

Do not mount within 0.25m of a luminaire.

Connecting

The MLS2001CDR connects to the LCM via an eight core, RJ45 plug terminated, patch lead. **All such patch leads must be segregated from mains wiring to preserve the detector SELV status that is provided by the LCM design.**

Ready-made patch leads in lengths of, 3m, 5m and 10m are available from Ex-Or. (See back page for Part Numbers.)

Where it is a requirement that the patch leads are protected by conduit it may prove more convenient to run the cables unterminated and attach the RJ45 connectors afterwards. In this case the cable used should be 4-twisted pair, 24awg multistranded, unscreened data cable to Category 5E standard, (e.g. Belden Datatwist 350). No strain-relief hoods should be fitted to the insulation displacement RJ45 connectors, due to the limited space available above the emplaced detector. **Note that the maximum allowable cable length between the MLS2001CDR and the CDW12U5 Connection Box is 100m.**

The wiring scheme used should follow either the T-568A or the T-568B Ethernet standards, and must give "1-1", "straight-through" connectivity between the two RJ45 connectors for all eight cores. **Note that this detector is not an Ethernet device and cannot be used with network Hubs and Switches.**

Plug the RJ45 connector at the detector station into the modular socket labelled "To CD Box" on the top of the detector module. and offer the detector to the backbox. When the bayonet fitting is engaged, twist the detector clockwise to retain it.

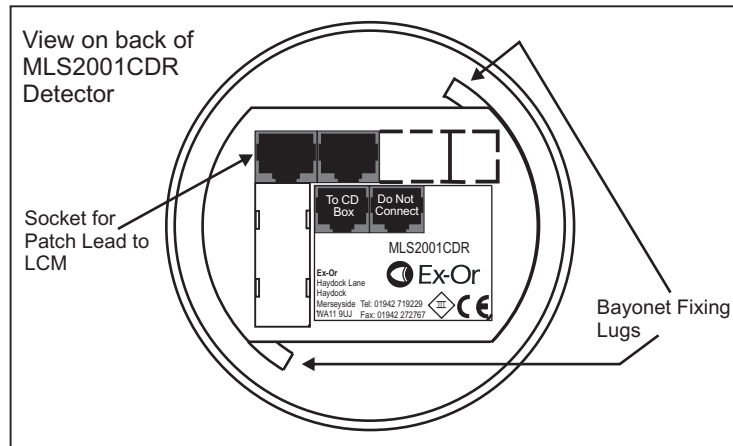

Commissioning

In the CDW12U5 and CDH4U5/CDH8U5 systems, all configuration information is held within the Lighting Control Modules themselves, not in individual detectors. Most of the configuration items are set up with the aid of a dedicated programme running on a portable PC which communicates with the LCM either by an infrared link, via one of the attached detectors, or by a specialised serial link into the LCM itself. However, when setting the actual light levels around which dimming or switching decisions are to be made, the system allows the commissioning engineer the same convenience as if he were dealing with traditional stand-alone detectors. An infrared programming tool, the HP2000 or HC5, is used to set the controlling or switching setpoint for the photocell. In all cases the setting is then transmitted from the detector to the LCM, where it is uniquely associated with the detector number being dealt with and will be preserved in the event of power failure. All settings can be re-programmed any number of times.

Setting the Regulating Photocell

Using the HP2000 Programmer, enter the Utilities menu and select 'Set Light Level'. Use the 'up' and 'down' buttons to manually adjust the light output from the luminaire(s) and when at the required level press and hold 'OK' to store. The luminaire(s) will blink to acknowledge a successful store operation.

Due to the fact that the photocell is on the ceiling looking down, it is not possible for measurements made with a lux meter on the working plane to remain constant when daylight illuminates the ceiling and the working plane to a differing extent. Therefore, products of this type should be regarded as capable of maintaining an APPROXIMATE light level only.

Setting the Switching Photocell

Now the desired switching light level must be arrived at either by waiting for an appropriate time of day or by a combination of manually switching off lights and perhaps masking windows. Using the HP2000 Programmer, enter the Utilities menu and select 'User Remote'. Scroll down to 'Scene 1' and press and hold the 'OK' button to store. The luminaire(s) will blink to acknowledge a successful store operation.

Testing

Detectors can be put into a temporary 10 second Off-delay mode to speed the process of checking their sensitivity and range settings using the HP2000 Utilities menu WalkTest option This mode expires automatically after a few minutes.

Dimensions

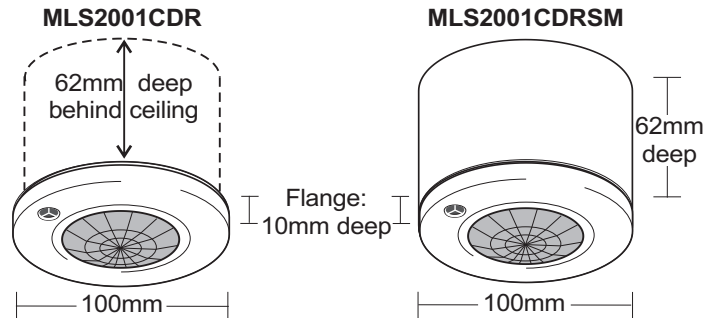

Technical Data

RECOMMENDED MAXIMUM MOUNTING HEIGHT: 3.0m

RANGE: Cone-shaped detection pattern, diameter (at floor level) = 2.4 x mounting height

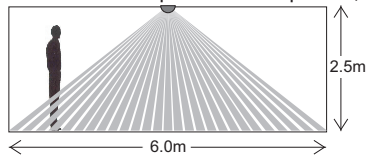

OPERATING VOLTAGE: 12V DC, SELV if installed correctly.

PHOTOCELL: Regulating

DEPTH REQUIRED BEHIND CEILING (FLUSH VERSION):

62mm plus an allowance for the minimum bend radius of the patch lead.

WEIGHT: 170g approx

COLOUR: White

MATERIAL: Flame retardant PC/ABS

IP RATING: 3X

Part Numbers

MLS2001CDR	360° Passive Infrared Presence Detector with Photocell, Flush Mount
MLS2001CDRSM	360° Passive Infrared Presence Detector with Photocell, Surface Mount
BT5E030GY	3m Detector Patch Lead.
BT5E050GY	5m Detector Patch Lead.
BT5E100GY	10m Detector Patch Lead

Ex-Or

Novar ED&S Limited
Haydock Lane, Haydock, Merseyside WA11 9UJ
Tel: +44 (0)1942 719229
Fax: +44 (0)1942 508753
Email: technicalsales.ex-or@honeywell.com
www.ex-or.com

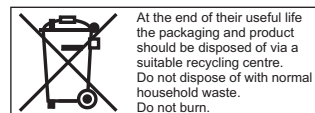

W4411E