

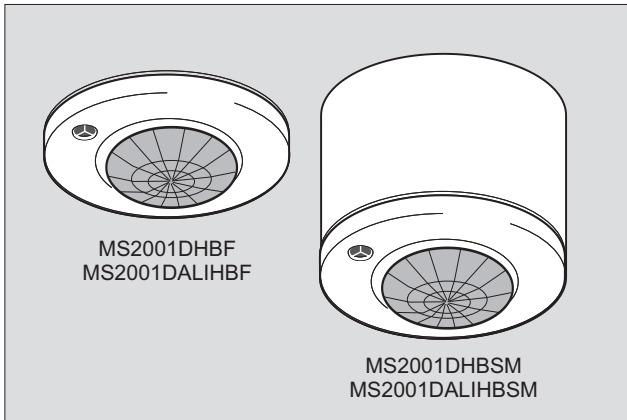

by Honeywell

Hi-Bay LightSpot
MS2001DHBFB & MS2001DHBBSM for DSI ballasts
MS2001DALIHBF & MS2001DALIHBSM for DALI ballasts



Installation and Commissioning
Instructions

Note: HP2000 (or HP18*) required for commissioning

* Please note that the HP18 offers different/limited programming options

Hi-Bay LightSpot: MS2001DHBF/SM for DSI ballasts and MS2001DALIHBF/SM for DALI ballasts

Only suitably qualified personnel should install this equipment.

Fixing

Flush Version: Depth required behind ceiling: 62mm from front flange plus an allowance for the minimum bend radius of the cable. Sinking box fits into a 89mm diameter hole in ceiling tile or plasterboard ceiling. Note: If the sinking box is being fitted to a hard substrate such as metal, increase the hole size to 91mm. To avoid damage to ceiling tile, do not overtighten. No access above the ceiling is required.

Surface Version: The housing may be secured to a hard surface or a BESA box. The unit fits into the housing with a simple bayonet action.

For aisle or corridor applications, there is an optimum orientation for approach:

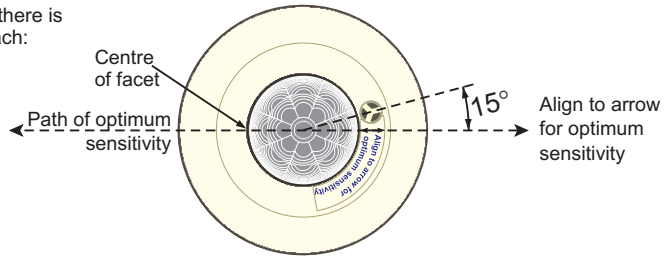

Note: When operating in 'Regulating Photocell' mode, a closed feedback loop is formed by the luminaire, the reflective surface beneath, and the photocell. For this control loop to function correctly, the photocell must have a good view of the reflected light only from the luminaire(s) under its control – NOT from adjacent luminaires not under its control. This means that the higher the detectors are mounted, the further apart they must be in order to ensure that they see mostly 'their own light'. Therefore, it is recommended that detectors are mounted on a pitch not less than 50% of the mounting height when using the regulating photocell function.

Connection

A 10A type C MCB is recommended for the supply. A means for disconnection must be incorporated in the fixed wiring according to the wiring regulations.

Control of a group of luminaires is achieved via the detector's two-wire digital control circuit. Each luminaire to be controlled must contain a digital regulating type ballast with the appropriate DSI or DALI input. Ballast types must not be mixed. Connect all ballasts in the control group (max 25) in parallel and also to the polarity-free digital output of the detector.

Each luminaire is controlled completely by its digital input and therefore would normally have a permanent power supply. If, however, it is desired to have manual wall switches, any or all of the fittings in a controlled group may also be controlled in the traditional way - by turning off the power. The control circuit will continue to operate properly even if some of the luminaires in the group have had mains power removed.

'OneSwitch' Dimming

OneSwitch dimming affords local control to the end-user whereby a simple, momentary, push-to-make wallswitch can be used to raise or lower the lighting level or to toggle the output ON/OFF. A short press of the switch (less than 1 second) will toggle the output status while a longer press will raise or lower the output. Each time the switch is pressed, the direction of dimming reverses. If the switch has not been pressed for 5 seconds, the direction will be up (brighter) - unless the output is already above 90% in which case the direction is down. If the switch is held continuously, and the output reaches maximum, the light output will remain at this level until the switch is released - a latching switch may be connected in parallel allowing the occupancy detection to be overridden on (Note: If the initial direction was down, when the output reaches minimum it will ramp back up automatically).

Setting the Regulating Photocell

This product is intended for use with high frequency regulating ballasts with digital control inputs. An infrared programming tool is required for programming the regulating light level set point. The setting is preserved in the event of a power failure and can be re-programmed any number of times.

Using the HP2000 Programmer, enter the Utilities menu and select 'Set Light Level'. Use the 'up' and 'down' buttons to manually adjust the light output from the luminaire(s) and when at the required level press and hold 'OK' to store. The luminaire(s) will blink to acknowledge a successful store operation.

On the HP18 Programmer, use the '+' and '-' buttons to manually adjust the light output from the luminaire(s) and when at the required level press '✓' to store. The luminaire(s) will blink to acknowledge a successful store operation.

Commissioning

The factory default settings will be appropriate for most applications. However, the installer does have the facility to re-programme a wide range of parameters and to set the regulating light level using the infrared programming tools. Please note that only the HP2000 gives access to the full range of parameters. Please read carefully the operating instructions that accompany the programmer prior to performing a programming operation.

Below is a table showing the pre-set factory settings and a brief explanation of each parameter. These parameters may be re-programmed any number of times and all settings will be retained in the event of a power loss.

Parameter	Programmer	Options	Pre-Set	Notes
Power Up	HP2000	On / Off	On	Sets the luminaire state at power up irrespective of occupancy. Useful in reducing start-up load following power cut. Power-up off - responds to occupancy after 30 seconds.
Response (or Mode)	HP2000 / HP18	Auto / Semi-auto	Auto	If set to auto, the presence detector switches the luminaire on and of automatically. If set to semi-auto (also known as absence mode), the luminaire will not turn on automatically when a person enters the area. It can be turned on using the hand-held controller or by toggling the power switch. When the area is vacated, the light will turn off automatically.
Off Delay	HP2000	1 min - 96 hrs / Disabled	20 mins	The time for which the luminaire will stay on following the last detected movement. A 10-second setting for walk-testing is also available.
	HP18	5, 10 or 20 mins		
On Sensitivity	HP2000	0-100	100	Sensitivity to movement when area is occupied. 100 = max
Start Lamps	HP2000	Max / Min	Max	Sets the level at which the lamps strike when turning on.
Entry Scene	HP2000	1-6	Scene 1	Sets which scene is recalled when an unoccupied area is entered.
Bright Out	HP2000	Yes / No	No	If set to yes, movement fails to refresh the off delay if the ambient light level exceeds 125% of the set level and the luminaire will switch off when the off delay has elapsed. (Note: Dimming must be set to 100%)
Dimming	HP2000	50%-100%	100%	Can be set to operate between 50% and 100% ballast output from max down to a bottom end limit when working on photocell control.
Photocell	HP18	Enabled/Disabled	100%	
Lamp Max	HP2000	10%-100%	100%	Can be set to limit the absolute maximum output of the ballast in all operating modes.
Fade to Off	HP2000	Yes / No	No	When no presence is detected, and after the off delay period, the lamps can fade out instead of switching off (approx 80 seconds to fade from 100% to 0%).
When Vacant	HP2000	Off / Min / Reg <25% / Scene 6 (latter via HP2000 only)	Off	These are the options for a vacant area after it has timed out. Luminaires can turn off, remain at minimum output, or regulate with a 25% output limit, until the next period of occupancy. If programmed to remain at minimum, to regulate below 25% (or go to scene 6 - available via HP2000 only), there is a programmable option to switch off after 3 times the Off delay (XTN).
Set-point Low	HP2000	0-1023	1023	Aiming point as photocell adjusts ballast output.
Set-point High	HP2000	0-1023	1023	Level above which photocell switches its output off (only if Bright Out = Yes).

Additional feature accessible under Utilities on HP2000:

100 Hour Burn-In	HP2000	Burn-in 100 hrs / Cancel / Resume	0 hr	See Application Note: AN4028
------------------	--------	-----------------------------------	------	------------------------------

Lens Mask

A lens mask (HBPIRLM) is available to mask end-of-aisle movement from being detected.

Important Additional Notes

- All terminals on this product are provided for final connections. It is not intended that the product be used as a junction box for looping cables.
- A means for disconnection must be incorporated in the fixed wiring in accordance with the current wiring regulations.
- Although nominally 12V, the dimming output is not SELV and therefore should be treated with the same respect as mains with regard to wiring practice. The 0V line of the dimming output is almost at Neutral potential.
- The dimming control output should be connected only to the control input of the ballasts - never to other detectors.
- Due to the fact that the photocell is on the ceiling looking down, it is not possible for measurements made with a lux meter on the working plane to remain constant when daylight illuminates the ceiling and the working plane to a differing extent. Therefore, products of this type should be regarded as capable of maintaining an APPROXIMATE light level only.

Electrical Connections

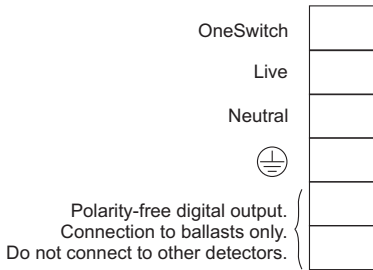

Dimensions

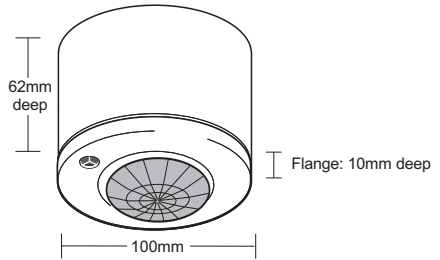

Technical Data

MAXIMUM RECOMMENDED MOUNTING HEIGHT: 16.0m

RANGE: 360° cone-shaped detection pattern, diameter (at floor level) = 1 x mounting height

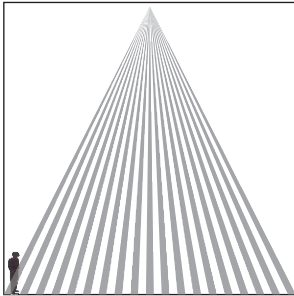

MINIMUM MOUNTING PITCH (SPACING): 0.5 x mounting height (regulating mode only)

OPERATING VOLTAGE: 230V 50Hz (UK & Europe)

PRODUCT RATING & RECOMMENDED CIRCUIT PROTECTION: 10 Amps

CAPACITY: 25 ballasts

OUTPUT: 2-wire digital polarity free

PHOTOCELL: Regulating

OFF DELAY: Adjustable via Programmer - factory pre-set to 20 minutes

DEPTH REQUIRED BEHIND CEILING (FLUSH VERSION): 62mm from front flange plus an allowance for the minimum bend radius of the cables.

WEIGHT: 200g approx

COLOUR: White

MATERIAL: Flame retardant PC/ABS

IP RATING: 4X

OPERATING TEMPERATURE: 0°C to 40°C

Ex-Or

Novar ED&S Limited
Haydock Lane, Haydock, Merseyside WA11 9UJ

Tel: +44 (0)1942 719229

Fax: +44 (0)1942 508753

Email: technicalsales.ex-or@honeywell.com

www.ex-or.com



At the end of their useful life the packaging and product should be disposed of via a suitable recycling centre. Do not dispose of with normal household waste. Do not burn.

