

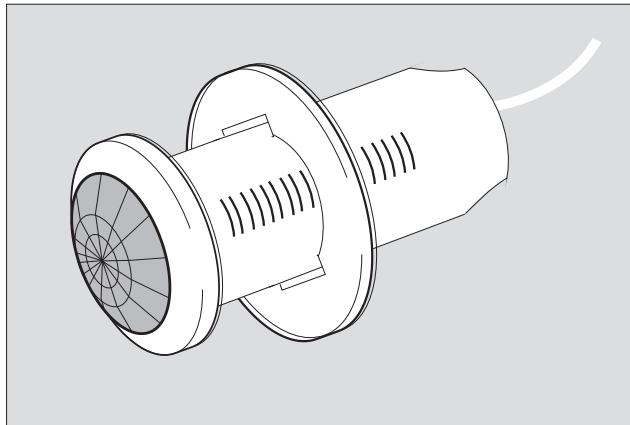

by Honeywell

**Hi-Bay LightSpot with photocell
MS1200PHBF**



**Installation and Commissioning
Instructions**

Note: HP2000 (or HP18*) required for commissioning
*Please note that the HP18 offers different/limited programming options

Ex-Or

Novar ED&S Limited
Haydock Lane, Haydock, Merseyside WA11 9UJ
Tel: +44 (0)1942 719229
Fax: +44 (0)1942 508753
Email: technicalsales.ex-or@honeywell.com
www.ex-or.com



At the end of their useful life
the packaging and product
should be disposed of via a
suitable recycling centre.
Do not dispose of with normal
household waste.
Do not burn.



W4444D

Hi-Bay LightSpot with photocell: MS1200PHBF

This is a high performance presence detector with photocell. In all operating modes, the photocell can hold lights off as a vacant area becomes occupied, and if the light level falls too low during the period of occupancy, the lights switch on. In 'Passive Mode' the lights do not switch off whilst the area is occupied no matter how much light is measured. In 'Active Mode' the photocell is able to switch the lights off whilst the area is occupied.

Fixing

Verify the small arrow on the bezel is inline with arrow on the main body.

This detector is suitable for flush mounting in a suspended ceiling tile, maximum 54mm thick and with a minimum clearance of 125mm between the front surface of the tile and the hard ceiling behind. The detector should be mounted in the centre of the group of luminaires to be controlled. Cut a 50mm diameter (64mm if using an FR64 flush ring or PB64 plasterboard fixing kit) circular hole in the tile, feed the flying lead and detector through the hole and secure into position with the locking ring. Twisting the locking ring will release the detector should this be necessary.

Note:

Minimum mounting pitch (spacing) utilising the photocell for MS1200PHBF = 0.5 x mounting height.

For aisle or corridor applications, there is an optimum orientation for approach, clearly indicated on the front of the product.

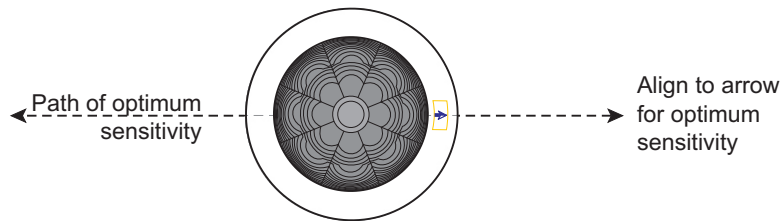

Electrical Connections

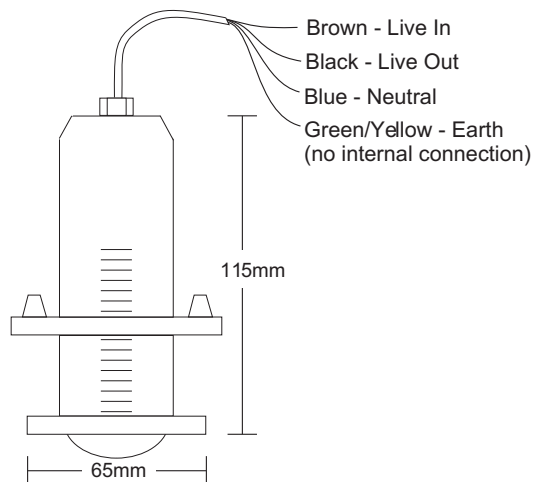

Commissioning

The factory default settings will be appropriate for most applications. However, the installer does have the facility to re-programme a wide range of parameters using an infrared programming tool. The full range of parameters is accessible via the HP2000; the HP18 offers different/limited programming options. Please read carefully the operating instructions that accompany the programmer prior to performing a programming operation.

Below is a table showing the pre-set factory settings and a brief explanation of each parameter. These parameters may be re-programmed any number of times and all settings will be retained in the event of a power loss.

Parameter	Options	Pre-set	Notes
Power up	on/off	on	Sets the luminaire state at power up irrespective of occupancy. Useful in reducing start-up load following power cut. Power-Up off - responds to occupancy after 30 seconds.
Response	auto/semi-auto	auto	If set to auto, the presence detector switches the luminaire on and off automatically. If set to semi-auto, the luminaire will not turn on automatically when a person enters the area. It can be turned on using the hand-held controller or by toggling the power switch. When the area is vacated, the light will turn off automatically.
Off delay	1 min-96 hrs / disabled 5,10 or 20 mins (HP18)	20 mins	The time for which the luminaire will stay on following the last detected movement. Also 10-second setting for walk-testing.
24hr Cycle	on/off	off	For use in 'Washroom mode' only - not applicable to this detector.
Photocell Mode	passive/active/ disabled	disabled	The operation of the built-in photocell is governed by the setting chosen and by values stored in the Upper and Lower thresholds (see diagram overleaf). Passive - The photocell will inhibit turn-on of the controlled load if sufficient natural light is available. It will not turn the load off whilst an area is occupied. Active - The photocell will turn the controlled load on and off as required whilst natural light levels fluctuate during a period of occupancy. This mode of operation operates in conjunction with a passing cloud timer (PCT). The PCT is asymmetrical in operation - the load will be switched on immediately that the light level falls below the lower set point, however, the load switches off only if the light level exceeds the upper threshold <i>continuously</i> for a period equal to the Off Delay. Disabled - The photocell has no effect.
Lower Threshold	0-254	254	Point at which photocell allows lights to switch on.
Upper threshold	0-254	254	Point where photocell turns lights off if Photocell is in Active mode.

Walk-test Mode

Walk-test mode is used to check that the detector is operating as required. The short off-delay enables the installer to check that lights are switching on when movements are made at the edge of the detection zone. It is easier to carry out a walk-test when the photocell is not holding the lights off.

1. Change the Off Delay to 10 seconds with the HP2000 by pressing 'Utilities/Walk Test/OK' or press 'TEST' on HP18.
2. Move around the area that is being controlled, stopping for 10 seconds to allow the lights to switch off, before moving and triggering the lights back on.

Lens Mask

A lens mask (HBPIRLM) is available to mask end-of-aisle movement from being detected.

Important Additional Notes

1. Only suitably qualified personnel should install this equipment.
3. A means for disconnection must be incorporated in the fixed wiring in accordance with the current wiring regulations.
3. This equipment switches lights no more frequently than would a responsible human occupant. However, manufacturers of some lighting types (e.g. '2D' luminaires) may specify a maximum number of switching cycles and/or a minimum on-time in order to achieve a predicted lamp life. Please check with the manufacturer of the luminaires to ensure that they are compatible with automatic controls in this respect.

W4444D

Setting the Photocell

1. If the lights are not already on, switch them on manually by pressing 'Utilities/User Remote/Luminaire+/OK' [HP2000] or 'On' [HP18]. Fluorescent lights do not reach full output until up to 15 minutes after being switched on, so ensure that the lights are fully warmed up before continuing. This stage may be omitted if the intention is to operate the detector's photocell in Passive Mode only [the detector must have already been programmed to Passive Mode].
2. Wait until the time of day when the natural light level is at the point below which you *would* want the lights to be on, and above which you *would not* want the lights to be on.
3. Start the internal self-programming mechanism by pressing 'Utilities/Set Light Level/OK' [HP2000] or 'Set' [HP18]. The detector takes a measurement, adds a small amount and stores the value in the Upper Threshold. Then it turns the lights off, makes another measurement and stores the value in the Lower Threshold. The lights now switch on again to acknowledge a successful programming operation.

The two switching thresholds have now been set, and the difference between them is equal to the contribution made by the electric lighting; this is the perfect amount of hysteresis to ensure that the lights will not oscillate. The thresholds may be read back and fine-tuned if necessary using the HP2000. Please note that the values are non-specific units i.e. not lux.

Note: The light level perceived by the detector at the moment immediately prior to a Download operation is shown momentarily on the HP2000 screen following the Download; this is a useful mechanism for troubleshooting.

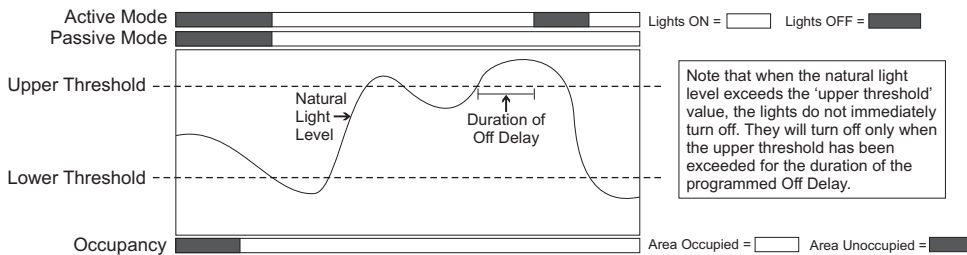

Technical Data

OPERATING VOLTAGE: 230V 50Hz (UK & Europe)
 RECOMMENDED CIRCUIT PROTECTION: 10 Amps
 MAXIMUM LOAD: 6 Amps
 MAXIMUM RECOMMENDED MOUNTING HEIGHT: 16 metres
 RANGE: 360° cone-shaped detection pattern, diameter (at floor level) = 1 x mounting height

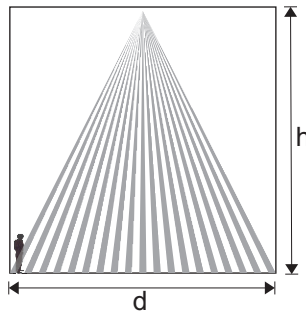

MINIMUM MOUNTING PITCH (SPACING): 0.5 x mounting height (when utilising the photocell - see note under 'Fixing')
 PHOTOCELL: Adjustable 50-5000 lux via HP2000/HP18
 OFF DELAY: Adjustable via Programmer - factory pre-set to 20 mins
 Options: 1 min - 96 hours / Disabled (via HP2000); 5, 10 or 20 minutes (via HP18) - plus 10-second Walk-test
 COLOUR: White
 MATERIAL: Flame retardant PC/ABS
 WEIGHT: 70g approx excluding cable
 IP RATING: 4X (Estimated - not tested)
 OPERATING TEMPERATURE: 0°C to 40°C