

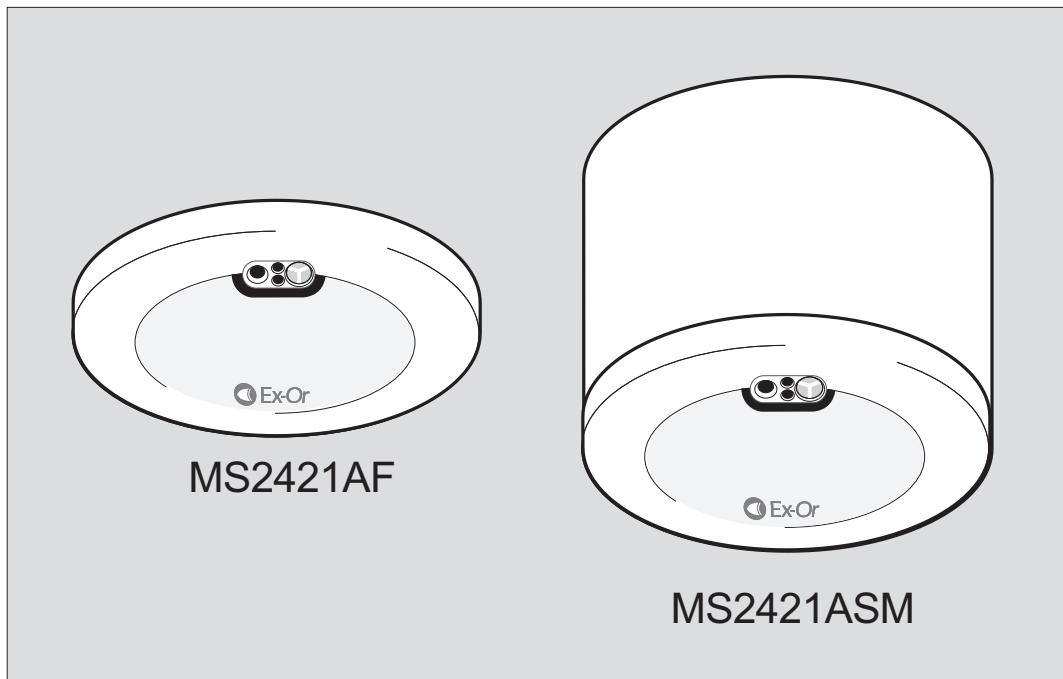

by Honeywell

**Gold Series LightSpot
for use with Analogue 1-10V ballasts
MS2421A**



**Installation and Commissioning
Instructions**

Note: HP2000 required for commissioning

Gold Series LightSpot for use with Analogue 1-10V Ballasts

Only suitably qualified personnel should install this equipment.

This high-performance presence detector forms a stand-alone lighting control unit. It is equipped with a regulating photocell to control analogue 1-10V ballasts (when using the detector's Dimming Output) and a volt-free output to fully extinguish analogue dimmable loads or for control of non-dimmable lighting loads. The detector incorporates Ex-Or's OneSwitch Dimming, allowing local manual operation of any controlled lighting load.

Location

This is an extremely sensitive movement detector; it is essential therefore that it be installed on a rigid surface that will not itself be subject to movement or vibration.

Please note that microwave detectors are not recommended for applications where there are large surface areas of metal, e.g. metal ceiling or floor tiles, as unpredictable sensitivity may result.

The units are graded according to four variations in operating frequency. Each type can be identified by different colour-coding on the detector label and carton. For reliable operation it is essential that units of the same colour code do not occupy adjacent positions in open-plan areas or in adjoining rooms (see below).

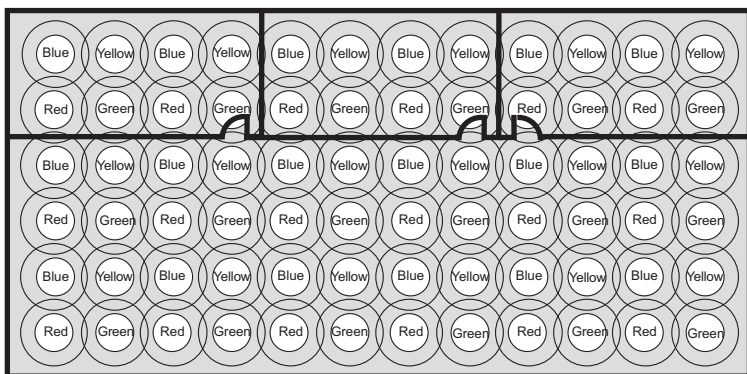

Note: Should it be necessary to order additional detectors for an existing installation and specific colour-coded detectors are needed, please add the following suffixes to the part number: Y = Yellow, B= Blue, G= Green, R = Red. (There is normally no need to specify the colour codes, as orders are dispatched with a suitable colour code mix.)

Fixing

MS2421ASM - The housing may be secured to a hard surface or a BESA box. The unit fits into the housing with a simple bayonet action.

MS2421AF - Depth required behind ceiling: 62mm from front flange plus an allowance for the minimum bend radius of the cable. Sinking box fits into a 89mm diameter hole in ceiling tile or plasterboard ceiling. To avoid damage to ceiling tile, do not overtighten. No access above the ceiling is necessary.

Please note: Do not position this product on a pitch narrower than 5m. Do not mount within 0.25m of a luminaire.

Electrical Connections

The detector should be connected in accordance with the diagrams opposite. Each luminaire to be controlled must contain an analogue regulating type ballast with the appropriate analogue input. Ballast types must not be mixed.

The analogue input terminals on the ballasts should be connected in parallel with each other and to the analogue 1-10V output terminals on the rear of the detector, observing the polarity. Also each of these analogue regulating ballast Live inputs (maximum load 6 Amps) must be provided by the Volt-free output (see 1st Wiring Example) from the detector.

When switching via the volt-free output multiple MS2421A detectors may be connected in parallel provided the controlled load does not exceed 6 Amps. (see 3rd Wiring Example).

DO NOT CONNECT DIMMING OUTPUTS TOGETHER.

OneSwitch

OneSwitch Dimming affords local control to the end-user whereby a simple, momentary, push-to-make wallswitch can be used to raise or lower the lighting level or toggle the output of the unit ON or OFF. A short press (less than 1 second) toggles the relay output from OFF to ON or from ON to OFF. A long press will ramp the analogue output either up or down with no effect on the volt-free output. If the output prior to pressing the switch is above 90% the output will ramp down; if below 90% it will ramp up. If the latest press and the current press are within 5 seconds of each other it will ramp in the opposite direction.

Commissioning

The units are supplied with the factory default settings shown below which render commissioning unnecessary in many applications. To make use of the programmable settings, an infrared commissioning tool is required (HP2000). A ten-second "Walk Test" time delay is selectable to aid commissioning

Factory Default Settings

These are the settings to which the units have been programmed before they leave the factory.

Parameter	Options	Default Setting	Options
Power up	ON/OFF	ON	Each of these settings can be re-programmed, if desired, by use of the infrared programming tool HP2000.
Response	Auto/Semi-auto	AUTO	
Off Delay	1min-96hrs or Disabled	20 min	
On Sensitivity	1-100	80	
Off Sensitivity	10-100% in 10% increments	80%	
Start Lamps	MAX/MIN	MAX	
Entry Scene	1-6	1	
Lamp Max	10%-100%	100%	
Dimming	REG 50%-100%	100%	
Fade to Off	YES/NO	NO	
When Vacant	10 Exit Scenes	NO	
PCell Rly	Disabled, Passive, Active	Disabled	
Set-Point Low	0-1023	1023	
Set-Point High	0-1023	1023	

Sensitivity to Movement

While the factory settings will be correct for many applications, the sensitivity can be adjusted if required.

ON Sensitivity (ON Range): This sets the detector's range when the lights are ON. (i.e. the space is Occupied) Choose setting from 1-100 where 1 is lowest and 100 is maximum. (Note: Choose the lowest level possible to give adequate detection.)

OFF Sensitivity (OFF Range): This sets the detector's range when the lights are OFF. (i.e. the space is Unoccupied/Vacant) Choose % setting from 10% to 100% where 10% = 10% of ON Sensitivity and 100% = same as ON Sensitivity. This is an approximation and should be tested on site during commissioning.

Generally the OFF Sensitivity should be significantly less than the ON Sensitivity as in the ON/Occupied state small movements of e.g. seated persons must be detected while in the OFF/Vacant state only the gross movements of persons entering the space need to be detected. This differential sensitivity prevents false triggering of the Presence Detection logic.

Like all programmable parameters, the sensitivity settings will be retained in the event of a power failure and can be re-programmed any number of times.

Commissioning the Photocell

Commissioning the setpoints for Photocell based control requires the HP2000 Hand-held Programmer. This tool should be used aimed squarely at the front of the Detector/Photocell at a distance of 1m although it can work at substantially greater distances if aimed carefully.

Regulating Only: For this mode the PCELL RLY action should be set to "DISABLED" and the lights will be on continuously during periods of occupancy. The Analogue 1-10V output dims the ballast(s) in the luminaires. It always tries to maintain a programmed light level on the working plane. It aims for the level stored in the parameter Set-point Low.

Sometimes it is convenient to limit the extent to which the presence detector with photocell is allowed to dim the light output of the luminaire(s). This can be done by setting the "DIMMING" parameter. This setting determines the range over which dimming can be operated e.g. setting 80% allows the luminaires to be dimmed down to a minimum of 20% of its possible output as natural light strengthens.

If it is desired to operate the lighting without any automatic photocell based control over the dimming process, (e.g. only manual control of dimming, by OneSwitch, and/or scene setting by HC5 Infrared Hand-held Controller is required) then the default values of 1023 should be retained in the parameters Set-point Low and Set-point High.

Programming the Regulating level: Place a light meter on the working plane underneath the presence detector with photocell. Adjust the light output of the luminaire up or down manually by infrared. (On the HP2000, select "UTILITIES" from the Main Menu and then "SET LIGHT LEVEL" from the UTILITIES Menu. The up and down Arrow keys allow adjustment of the light level up and down whilst pointing the handset at the presence detector with photocell.) When the light meter reads the desired level, press and hold the central "OK" button until the lights "blink" to acknowledge that the

photocell reading has been stored in the Set-point Low parameter. This is the control set-point for the regulating process which tries to maintain this photocell reading at all times by dimming or brightening the lights.

Switching the Lighting Load:

In addition to dimming the lighting load via the 1-10V output, the load can also be controlled by the relay according to natural light level. This form of control is governed by the setting of the parameter PCELL RLY. There are three options for this parameter:-

DISABLED: In his mode the photocell has no effect upon the operation of the relay - it will switch only according to detected occupancy.

PASSIVE: In this mode the relay will be inhibited from closing if the area is entered when the ambient light level is above Set-point Low. If during the period of occupancy, the light level falls below Set-point Low, then the lights will switch on. In this mode the lights will never switch off during a period of occupancy - no matter how bright it becomes.

ACTIVE: This is the same as PASSIVE mode except that, additionally, the lights will switch off if the light level exceeds Set-point High even if the area is occupied. For the switch-off to occur, the light level must persist at this high level for the full duration of what is called a "Passing Cloud Timer" (PCT). The PCT is usually of the same duration as the Off-delay used by the Presence Detection logic; however when an unusually long Off-delay is configured the PCT is automatically capped at 20 minutes. If the light level falls below Set-point Low during a period of occupancy, then the lights are switched on immediately without any delay.

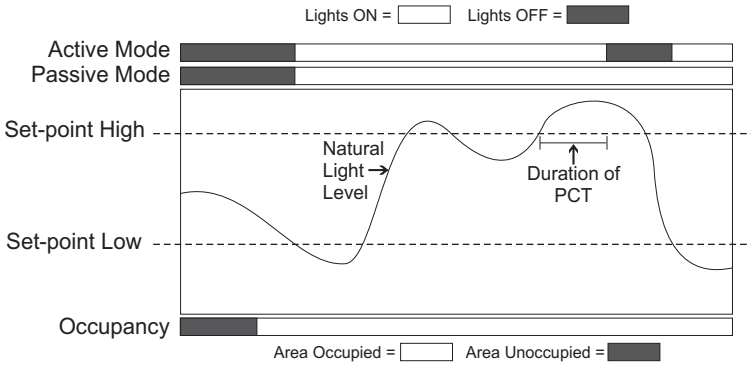

Programming the Set-points:

1) Simple PCELL RLY Switching Control:

i) If PCELL RLY-ACTIVE switching action is required it is important that the lights are switched on at least 15 minutes before this procedure is undertaken to allow the tubes to reach full output. For PCELL RLY-PASSIVE switching action this is not necessary.

ii) Download the settings already established within the Detector for non-Photocell related features to the HP2000. Edit the Photocell setting to ACTIVE or PASSIVE as required. Upload the whole configuration to Detector.

iii) Wait until the appropriate time of day for, or use blinds to create, the natural light level, as measured with a light meter, below which you **would** want the lights to be on and above which you **would not** want the lights to be on.

iv) Start the internal self-programming operation by selecting UTILITIES/SET LIGHT LEVEL on the HP2000 and pressing and holding the "OK" button. The Detector takes a Photocell reading, adds a small margin and stores the resulting value as Set-point High. It then switches off the controlled lights and takes another Photocell reading which it stores as Set-point Low. The lights are now switched on again, completing the acknowledgement "blink". The OK button can now be released. Note that the difference between the two Set-point values, the Switching Hysteresis, is equal to the contribution to total light made by the controlled luminaires. This is the ideal amount of hysteresis to prevent oscillation without compromising control accuracy.

2) Regulating Control overlaid by PCELL RLY Switching Control

First carry out the commissioning procedure described for **Regulating Only** control (under Photocell Commissioning). When the **Regulating Only** commissioning procedure has been carried out the HP2000 parameter Set-point Low within the Detector has acquired a new, non-default value. This value should be read in a full download from the Detector to the HP2000 and retained.

The Set-point High value should now be manually edited on the HP2000 screen to be about 25% higher in the same units, e.g. if a download from the Detector to the HP2000 shows that 429 has been automatically stored into the Set-point Low parameter, then the Set-point High value should be manually edited to 535 or 536. The PCELL RLY action should be set to "ACTIVE" or "PASSIVE", as required, and the whole configuration then uploaded to the Detector.

User Overrides

The end-user can configure a number of lighting scenes that can be recalled using a hand-held override. With an HC5 hand-held controller lighting can be overridden OFF or ON, or a set level can be chosen. Regulating and switched loads can be adjusted independently through a combination of OneSwitch Dimming and the HC5 Hand-held Controller.

Wiring Examples

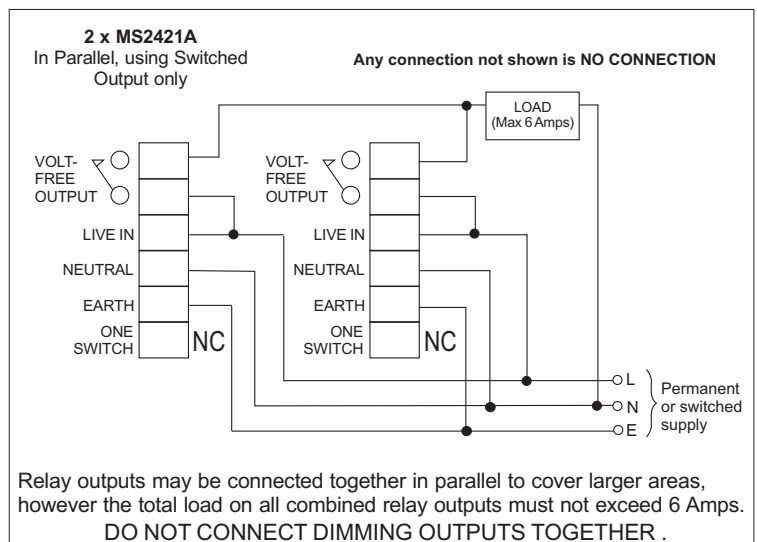
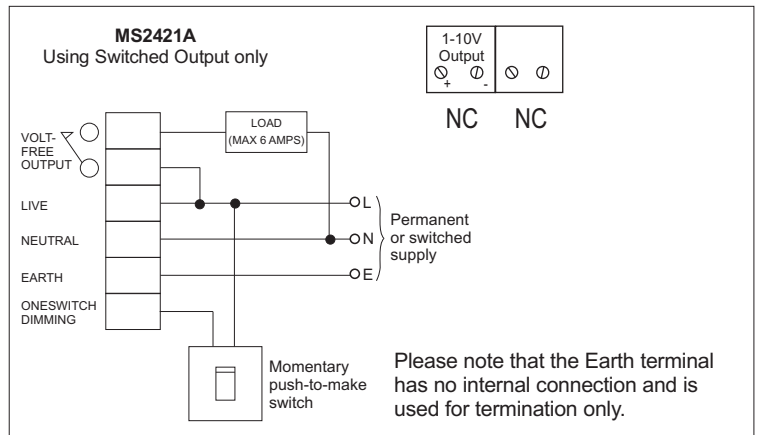
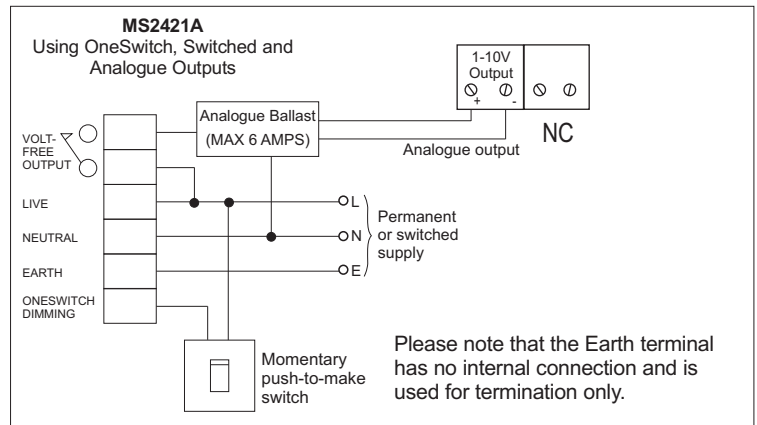

Relay outputs may be connected together in parallel to cover larger areas, however the total load on all combined relay outputs must not exceed 6 Amps. **DO NOT CONNECT DIMMING OUTPUTS TOGETHER.**

Dimensions

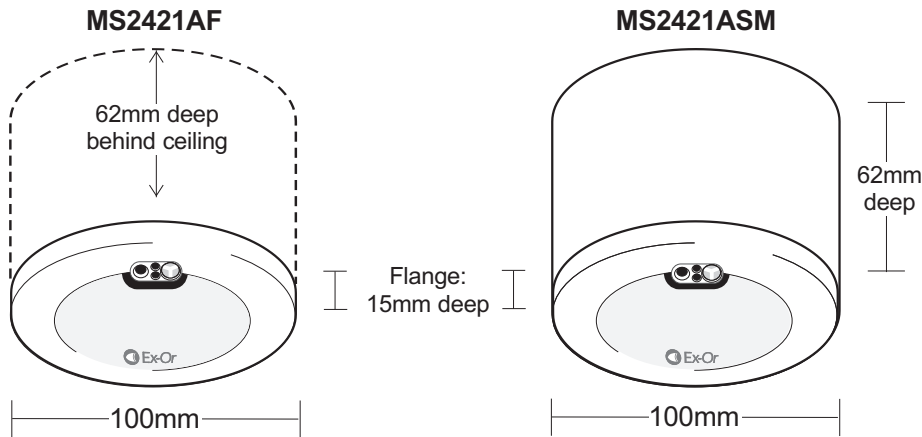

Technical Data

MAXIMUM RECOMMENDED MOUNTING HEIGHT: 3.0m

RANGE: Approx 7m dia at 2.4m ceiling height

OFF DELAY: 1 minute - 96 hours/Disabled plus 10-second Walk-test Mode

PHOTOCELL: Passive/Active/Regulating adjustable 50-5000 lux

OPERATING VOLTAGE: 230V 50Hz (UK & Europe)

PRODUCT RATING AND RECOMMENDED CIRCUIT PROTECTION: 10 Amps

MAXIMUM RECOMMENDED LOAD (VOLT-FREE): 6 Amps

MAXIMUM RECOMMENDED LOAD (ANALOGUE 1-10V): 20 Ballasts

DIMMING OUTPUT: Analogue 1-10V

COLOUR: White

MATERIAL: Flame retardant PC/ABS

WEIGHT: 300g

IP RATING: 2X

Important Additional Notes

1. All terminals on this product are provided for final connections. It is not intended that the product be used as a junction box for looping cables.
2. A means for disconnection must be incorporated in the fixed wiring in accordance with the current wiring regulations.
3. Although nominally 12V, the dimming output is not SELV and therefore should be treated with the same respect as mains with regard to wiring practice. The 0V line of the dimming output is almost at Neutral potential.
4. The dimming control output should be connected only to the control input of the ballasts - never to other detectors.
5. Due to the fact that the photocell is on the ceiling looking down, it is not possible for measurements made with a lux meter on the working plane to remain constant when daylight illuminates the ceiling and the working plane to a differing extent. Therefore, products of this type should be regarded as capable of maintaining an APPROXIMATE light level only.
6. This equipment switches lights no more frequently than would a responsible human occupant. However, manufacturers of some lighting types (e.g. '2D' luminaires) may specify a maximum number of switching cycles in order to achieve a predicted lamp life. Please check with the manufacturer of the luminaires to ensure that they are compatible with automatic controls in this respect.
7. The detectors are extremely sensitive to movement; they must be mounted on a solid surface which has no movement whatsoever.
8. This equipment should be used to control only those ballasts powered from the same phase as the detector.

Ex-Or

Novar ED&S Limited
Haydock Lane, Haydock,
Merseyside WA11 9UJ

Tel: +44 (0)1942 719229

Fax: +44 (0)1942 508753

Email: technicalsales.ex-or@honeywell.com

www.ex-or.com

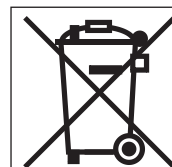

At the end of their useful life the packaging and product should be disposed of via a suitable recycling centre. Do not dispose of with normal household waste. Do not burn.



W4475D