



by Honeywell

**IP65 BattenFit Sensor
MSB1001T - Switching
MSB1001PT - Switching with photocell**



**Installation and Commissioning
Instructions**

Note: HP2000, HP10* or HP18* required for commissioning

* Please note that the HP10/HP18 offer different/limited programming options

IP65 BattenFit Sensor: MSB1001T - Switching
MSB1001PT - Switching with photocell

Only suitably qualified personnel should install this equipment.

This passive infrared presence detector is designed to be fitted to a batten-style luminaire.

Installation

1. Remove the M20 knockout from the end cap of the luminaire.
2. Pass the sensor wires through from the outside and insert the threaded end of the sensor into the hole.
3. A polarising plate can be made in order to prevent rotation of the sensor - an example design is given on page 3 (Fig.5).
4. If a polarising plate is to be used, pass the wires through the slot and position the polarising plate against the inside face of the end cap. Ensure that the tab is positioned correctly i.e. at the ceiling side, away from the lamp.
5. Fit and tighten the locknut.
6. Connect the wires in accordance with the wiring instructions.

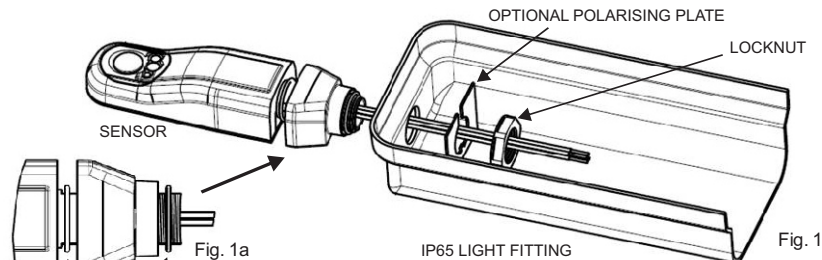

ENSURE THAT THE TWO O-RINGS ARE FITTED AS SHOWN

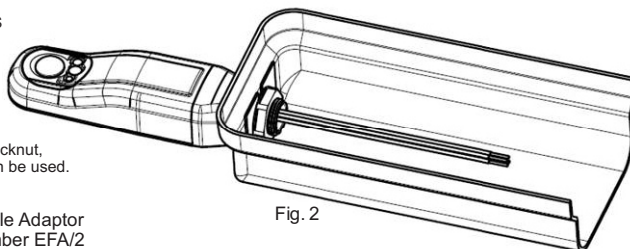

If there is insufficient space for the locknut, the adaptor shown below (Fig. 3) can be used.



Angled Washer Kit (supplied)

If the light fitting has an angled (drafted) end face then use the kit provided as shown (Fig. 4).

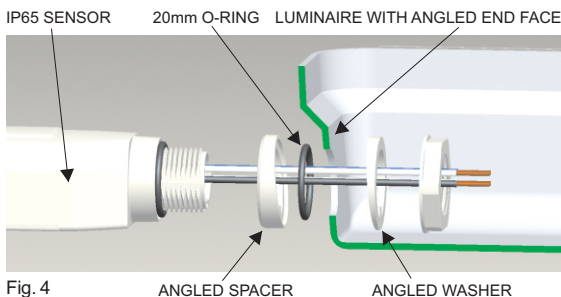

Polarising Plate (not supplied)

The purpose of the polarising plate is to ensure that the sensor does not rotate from the correct position, i.e. pointing vertically downwards, during transport or installation.

The two overall dimensions marked 'SEE TEXT' need to be made such that when the plate is positioned against the inner face of the luminaire end cap, it cannot rotate.

The 3.5mm 'tab' should be located closest to the ceiling (away from the lamp). The 6.0mm slot is optional and is to allow the wires to pass through for ease of assembly.

Material can be plastic sheet, minimum thickness 1.0mm, recommended thickness 1.5-2.0mm, or mild/stainless steel sheet, minimum thickness 0.6mm, recommended thickness 1.0-1.6mm.

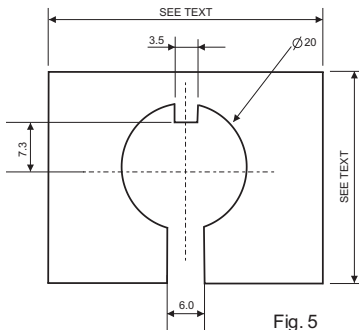

Fig. 5

Electrical Connections

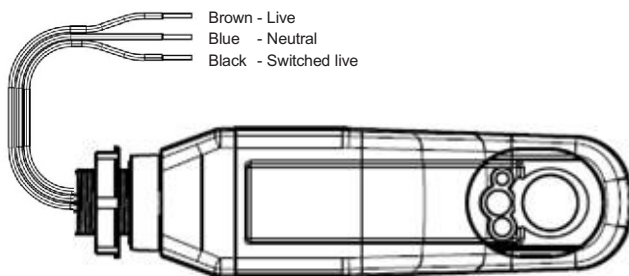

Fig. 6

Always check product label before connecting.

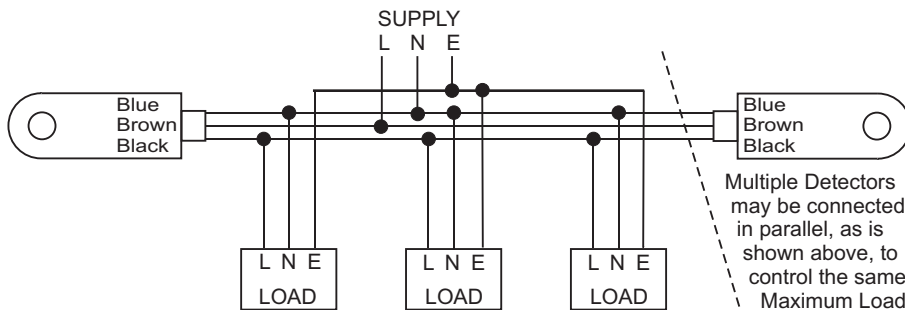

Fig. 7

Maximum Total Load not to exceed that specified for a Single Detector

Detection Profile

Plan View

Detection pattern is a 360° cone shape.
Diameter is 2.25 x the mounting height.

The squares show the arrangement
of the detection pattern.

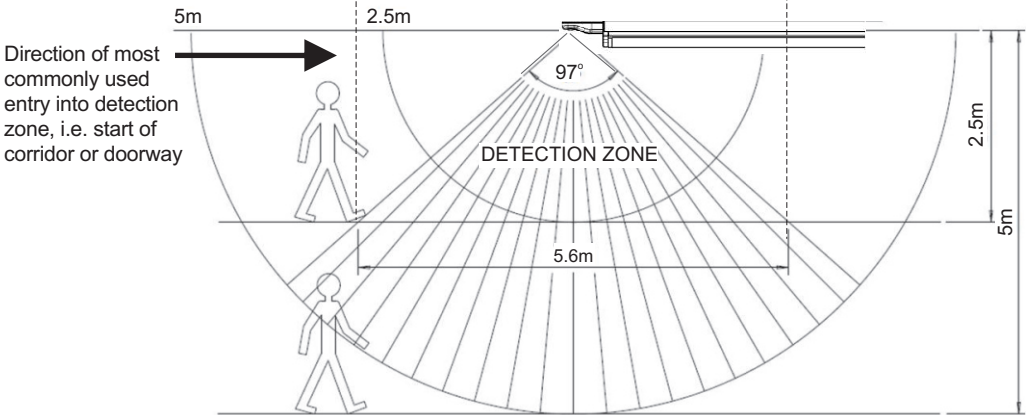
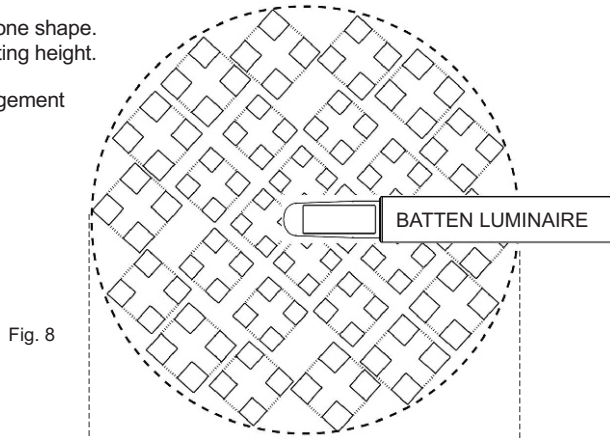

If the distance between the bottom of the sensor and the bottom of the end cap exceeds 59mm (in the case of square covers) or 82mm (for rounded covers), there may be a blind spot in the detection zone.

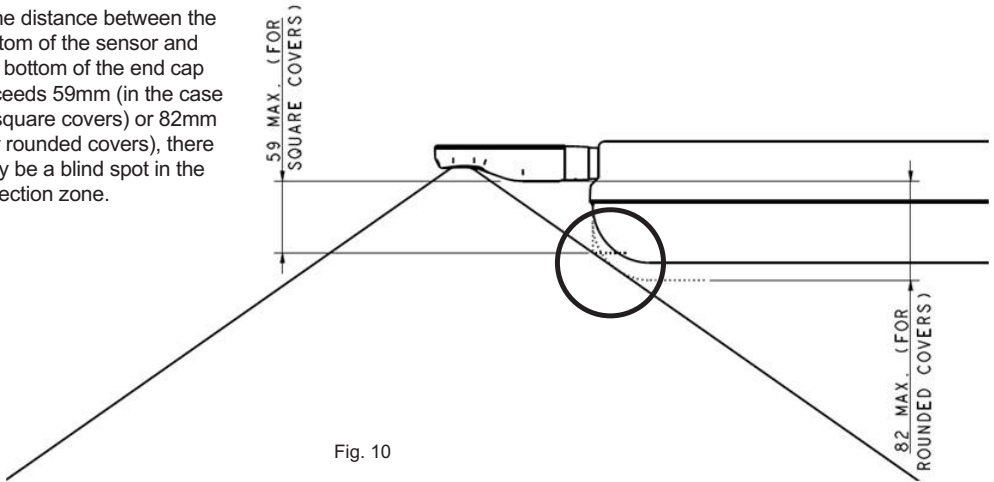

Fig. 10

Walk Testing

In order to verify the installation, there is an inbuilt facility (Walk Test Mode) to temporarily reduce the time delay to 10 seconds. An HP2000, HP10 or HP18 Programmer is required to access this facility.

Using the HP10 or HP18:

Use the DIL switches (HP10) or press the 'TEST' button (HP18) to enable walk test mode.

Move around the area that is being controlled, stopping for 10 seconds to allow the lights to switch off, before moving and triggering the lights back on.

Re-programme the desired Off Delay once testing is complete (MSB1001PT only).

Using the HP2000:

Go to the Utilities menu, place the cursor over 'Walk Test', point the programmer at the detector and press OK.

Move around the area that is being controlled, stopping for 10 seconds to allow the lights to switch off, before moving and triggering the lights back on.

After 5 minutes, the time-out will be restored to what it was before walk test was enabled.

Notes on Walk Testing:

- During walk test, after the lights have turned off, wait 5 seconds before moving again because the sensitivity is deliberately reduced for a few seconds following switch off.
- Sensitivity is greater when approaching the circular footprint at a tangent rather than heading towards the centre (see Fig. 8).
- Most luminaires take approximately 1 second to strike after presence has been detected.
- The detection pattern is cone-shaped which means that when standing at the very edge of the detection footprint only a person's feet will be visible (see Fig. 9).

Photocell

The photocell (MSB1001PT only) can be programmed to operate in one of two ways: Active or Passive. (Factory default setting is 'Passive'.)

In all operating modes, the photocell can hold lights off as a vacant area becomes occupied, and if the light level falls too low during the period of occupancy, the lights switch on. In 'Passive Mode' the lights do not switch off whilst the area is occupied no matter how much light is measured. In 'Active Mode' the photocell is able to switch the lights off whilst the area is occupied.

Setting the Photocell

1. If the lights are not already on, switch them on manually by pressing 'Utilities/User Remote/Luminaire+/OK' [HP2000], or 'Up' [HP10] or 'On' [HP18]. Fluorescent lights do not reach full output until up to 15 minutes after being switched on, so ensure that the lights are fully warmed up before continuing. This stage may be omitted if the intention is to operate the detector's photocell in Passive Mode only [the detector must have already been programmed to Passive Mode].
2. Wait until the time of day when the natural light level is at the point below which you *would* want the lights to be on, and above which you *would not* want the lights to be on.
3. Start the internal self-programming mechanism by pressing 'Utilities/Set Light Level/OK' [HP2000], or 'Store' [HP10] or 'Set' [HP18]. The detector takes a measurement, adds a small amount and stores the value in the Upper Threshold. Then it turns the lights off, makes another measurement and stores the value in the Lower Threshold. The lights now switch on again to acknowledge a successful programming operation.

The two switching thresholds have now been set, and the difference between them is equal to the contribution made by the electric lighting; this is the perfect amount of hysteresis to ensure that the lights will not oscillate. The thresholds may be read back and fine-tuned if necessary using the HP2000. Please note that the values are non-specific units i.e. not lux.

Note: The light level perceived by the detector at the moment immediately prior to a Download operation [HP2000 only] is shown momentarily on the HP2000 screen following the Download; this is a useful mechanism

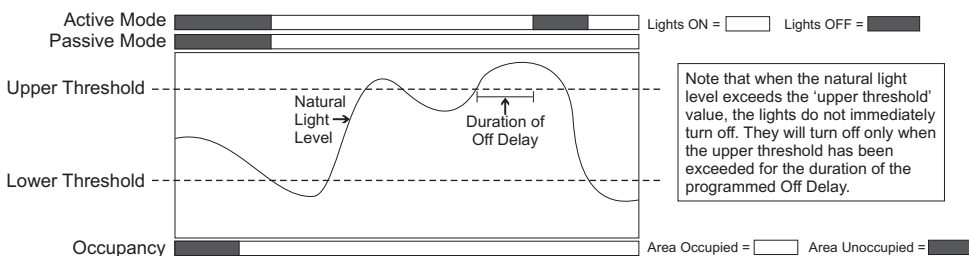
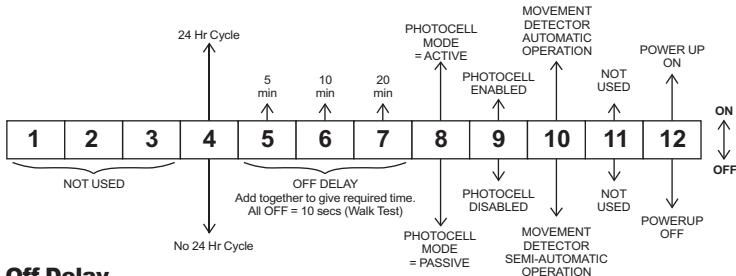

Fig. 11

HP10 Parameter Options (MSB1001PT only except Walk Test)



Off Delay

The Off Delay may be set between 5 and 35 minutes (MSB1001PT only). A 10-second Off Delay is available for walk-testing the product. In a typical office environment a 20-minute Off Delay is usually satisfactory.

Movement Detector Operation (Automatic/Semi-Automatic)

Where absence detection is required (ie the user manually turns lights ON if required but lights still turn off automatically once an area is vacated), semi-automatic operation can be set via the programmer.

Power Up Setting (On/Off)

Set to ON the detector will automatically switch its outputs on when Mains is applied. If set to OFF, the detector will power up without turning its outputs on, wait for 30 seconds and THEN look for movement. Only if the area is occupied will the output switch on at this time. The detector must be set to Power Up ON when used in conjunction with semi-automatic operation.

Photocell Operation (Passive/Active/Disabled)

The MSB1001PT has an in-built photocell. The photocell has three modes of operation - Passive, Active and Disabled. Its operational behaviour is governed by the setting chosen and by the values stored in the Upper and Lower thresholds (see diagram overleaf).

Passive - The photocell will inhibit turn-on of the controlled load if sufficient natural light is available. It will not turn the load off whilst an area is occupied

Active - The photocell will turn the controlled load on and off as required whilst natural light levels fluctuate during a period of occupancy. This mode of operation operates in conjunction with a passing cloud timer (PCT). The PCT is asymmetrical in operation - the load will be switched on immediately that the light level falls below the lower set point, however, the load switches off only if the light level exceeds the upper threshold *continuously* for a period equal to the Off Delay.

Disabled - The photocell has no effect.

24hr Cycle (Yes/No)

Not applicable.

Defaults (where applicable)

The units are supplied with factory default settings (Power-Up On, fully Automatic operation, a 20 minute Off Delay, no 24hr Cycle, Passive Photocell). Programming is carried out using an infrared programming tool. Please note that the full range of parameters is accessible via the HP2000; the HP10 and HP18 offer different/limited programming options.

Dimensions

All dimensions in mm

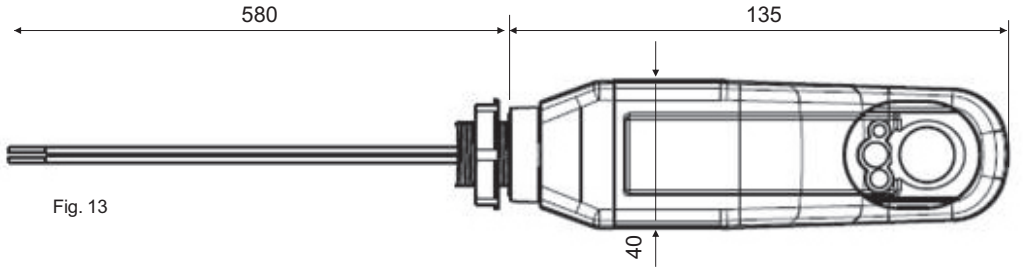
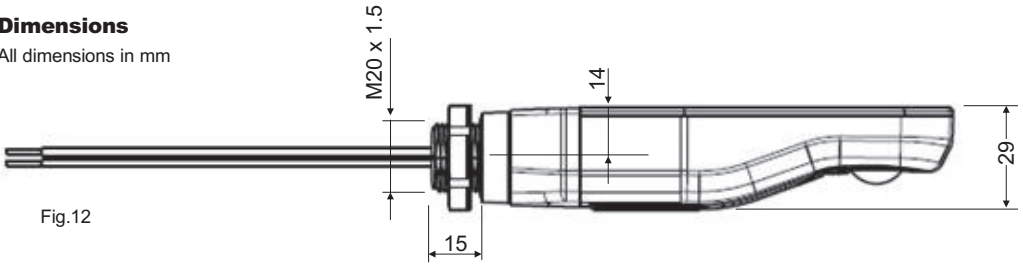

Technical Data

OPERATING VOLTAGE: 230V~ 50Hz (UK & Europe)

POWER CONSUMPTION: <0.5W

CAPACITY: 2A Switching

MAXIMUM NUMBER OF BALLASTS: 4 (Electronic or HF Ballasts)

WEIGHT: 120g

COLOUR: White (RAL9010)

MATERIAL: Flame retardant PC/ABS

IP RATING: 65

Important Additional Notes

1. A means for disconnection must be incorporated in the fixed wiring in accordance with the current wiring regulations.
2. Due to the fact that the photocell (MSB1001PT) is on the ceiling looking down, it is not possible for measurements made with a lux meter on the working plane to remain constant when daylight illuminates the ceiling and the working plane to a differing extent. Therefore, products of this type should be regarded as capable of maintaining an APPROXIMATE light level only.
3. This equipment switches lights no more frequently than would a responsible human occupant. However, manufacturers of some particular lighting types (e.g. '2D' luminaires) may specify a maximum number of switching cycles in order to achieve a predicted lamp life. Please check with the manufacturer of the luminaires to ensure that they are compatible with automatic controls in this respect.

Ex-Or

Novar ED&S Limited
Haydock Lane, Haydock, Merseyside WA11 9UJ

Tel: +44 (0)1942 719229

Fax: +44 (0)1942 508753

Email: [@com](mailto:technicalsales.ex-or)

www.ex-or.com



At the end of their useful life the packaging and product should be disposed of via a suitable recycling centre. Do not dispose of with normal household waste. Do not burn.



W4483E