

Connect - Lighting control modules and plug-in connection centres

MLS Connect Digital Remote PIR Sensors for CDW12U5, CDH4U5 & CDH8U5 LCMs

CDW12U5 Programmable Connection Centres and CDH4U5/CDH8U5 Hard-Wired Intelligent Lighting Control Modules support a range of dedicated high-performance lighting control sensors to deliver premium energy saving and enhanced comfort and productivity. Sensors contain a photocell to monitor total light levels, allowing the light output of dimmable luminaires to be adjusted to suit the level of natural light available.

The range of PIR sensors (see Data Sheet D4123 for Microwave options) offer enhanced sensitivity and range: 7m Micro Detection, 10m Macro Detection. The range includes variants with tilting lenses with Mid-Bay and Hi-Bay versions for mounting at height. All the following are available in flush and surface mount versions:

MLS3000CDR - 360° PIR sensor with photocell

MLS3003CDR - 360° PIR sensor with tilting lens

MLS3003CDRMB - Mid-Bay 360° PIR sensor with tilting lens, for mounting heights of up to 12m

MLS3003CDRHB - Hi-Bay 360° PIR sensor with tilting lens, for mounting heights of up to 16m

All contain an infrared port that can be used both for local control from a hand-held device when in service and for initial commissioning of the CDW12U5/CDH4U5/CDH8U5 Intelligent LCM system. Sensors connect to the LCM via RJ45 patch leads and all are SELV devices when properly installed and connected. Ready-made patch leads are available in lengths of 3m, 5m and 10m.

Tilting Lenses enable the precise area of sensing to be adjusted as required and extended in one direction (useful where the ideal mounting location is not available). The unique anti-tamper 'twist-2-lock' feature locks the detection area in position.

High-Accuracy Lens Masks (included) allow highly defined detection areas. Virtual corridors can be easily created, so that passing traffic doesn't unnecessarily trigger sensors.

Sensors offer the following innovative features:

Absence by Day, Presence by Night: When natural light is available, Detectors will operate in absence mode – lights need to be manually switched switch and will switch off automatically when the space is vacated. During hours of darkness lights will switch both on and off automatically.

Auto Recovery in Absence Mode: Following automatic switch off of lights, movement detected within a short pre-determined time window will cause the lights to automatically switch back on without the need to press the manual switch.

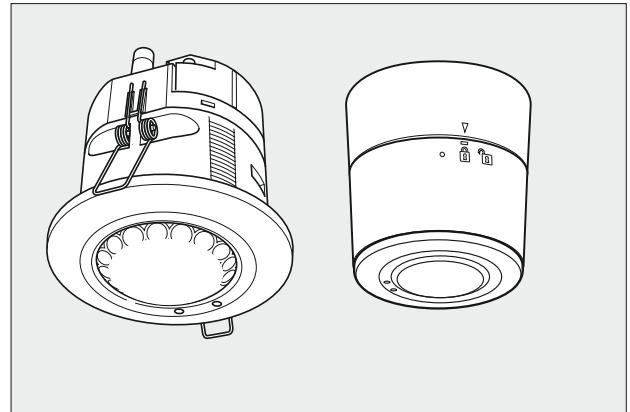

Auto Absence Detection Mode: Following first installation, if Sensors are set to operate in Absence Mode, they will function in fully automatic (Presence) Mode, until an initial input switch event is detected.

Advanced Occupancy Lifecycle: Individually programmable, Occupied, Transition, Background and Unoccupied Modes enable sophisticated and convenient lighting control schemes to be simply executed.

Commissioning

With the CDW12U5 and CDH4U5/CDH8U5 LCM systems, all configuration information is held within the Connection Centre itself, not the individual detectors. Most of the parameters are set up with the aid of a dedicated programme running on a portable PC which communicates with the LCM either by an infrared link, via one of the attached detectors, or by a specialised serial link into the LCM itself.

When setting the actual light levels around which dimming or switching decisions are made, the system utilises the same simple and convenient method as used for Ex-Or's traditional stand-alone detectors. An infrared programming tool (QuickSet Pro, HP2000 or HC5A) is used to set the controlling or switching set-point for the photocell. The setting is then transmitted from the detector to the LCM where it is uniquely associated with that particular detector. The setting will be preserved in the event of power failure. All settings can be re-programmed any number of times. (See 'Setting the Regulating Photocell' and 'Setting the Switching Photocell' sections of installation instructions for details of setting procedure.)

Please check www.ex-or.com to ensure this is the most recent issue - Ref: D4140B

Installation and Fixing

Installing Sensor into Ceiling Tile

Fixing to Ceiling - Standard Method

Alternatively, the Secure Locking Method can be used (LOCKRING available separately) - see Installation Instructions for details.

Connections

Sensors connect to the LCM via an eight core, RJ45 plug terminated, patch lead. **All such patch leads must be segregated from mains wiring to preserve the sensor's SELV status that is provided by the LCM design.**

Where required to protect patch leads by conduit, it may be more convenient to run the cables unterminated and attach the RJ45 afterwards. See installation instructions for details.

Max allowable cable length between sensor and CDW12U5 is 100m.

Fixing to Ceiling - Surface Mounting

Product variants with 'SM' suffix are supplied with the surface fitting kit as standard (this is available separately as SURFMT). The sensor may be mounted to any suitable surface but is most commonly fixed to a conduit stop-end (BESA) box or bushed to trunking.

Positioning

The sensor should be positioned on the ceiling in the centre of the occupied space. It is available in three different mounting heights (see table below). Ensure maximum mounting height is not exceeded. Avoid mounting next to AC unit. Do not mount within 0.25m of a luminaire.

Type	Aspect Ratio (diameter : height)		Max recommended mounting height
	Micro Detection - High Sensitivity	Macro Detection - Standard Sensitivity	
Office	2.8:1 (7m diameter @ 2.5m height)	4:1 (10m diameter @ 2.5m height)	3.5m
Mid-Bay	N/A	2:1 (20m diameter @ 10m height)	12m
Hi-Bay	N/A	1.9:1 (27m diameter @ 14m height)	16m

Dimensions

Flush Mount: 73mm diameter, 75mm height, 87mm base diameter.

Surface Mount: 93mm diameter, 107.6mm height, 87mm base diameter.

Technical Data

OPERATING VOLTAGE: 12V DC, SELV if installed correctly
 PHOTOCELL Regulating
 WEIGHT: 106g - MLS3000CDR
 117g - MLS3003CDR
 COLOUR: White RAL9010
 MATERIAL: Flame retardant PC/ABS
 IP RATING: 4X

Accessories

QuickSet Pro Digital 2-Way Programming Tool
Menu-driven LCD Programmer with automatic equipment recognition and parameter download facilities.

HC5A Universal Hand-held Controller
Allows manual override. Supplied with wall bracket.

Part Numbers

MLS3000CDRF	360° PIR Sensor - flush	BT5E030GY	3m Detector Patch Lead
MLS3000CDRSM	360° PIR Sensor - surface	BT5E050GY	5m Detector Patch Lead
MLS3003CDRF	360° PIR Sensor with tilting lens - flush	BT5E100GY	10m Detector Patch Lead
MLS3003CDRSM	360° PIR Sensor with tilting lens - surface	QUICKSET PRO	QuickSet Pro Digital 2-Way Programming Tool
MLS3003CDRMBF	Mid-Bay 360° PIR Sensor with tilting lens - flush	HC5A	Universal Hand-held Controller c/w wall bracket
MLS3003CDRMBSM	Mid-Bay 360° PIR Sensor with tilting lens - surface	SURFMT	Surface-mount Kit (supplied with SM versions)
MLS3003CDRHBF	Hi-Bay 360° PIR Sensor with tilting lens - flush	LOCKRING	Secure Lockring
MLS3003CDRHBSM	Hi-Bay 360° PIR Sensor with tilting lens - surface		