

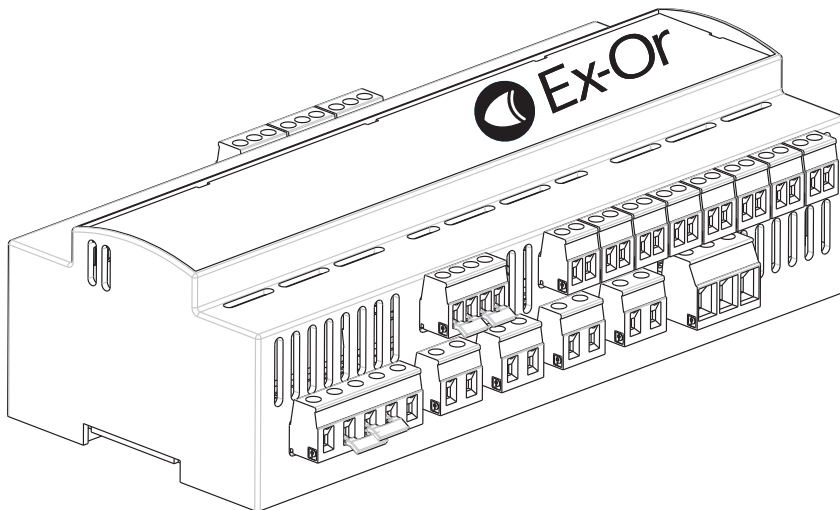

by Honeywell

CDH4U5
4-Channel Programmable
Intelligent Lighting Control Module



Installation and Commissioning Instructions

Introduction

The CDH4U5 is an intelligent LCM providing connections for multiple luminaires*, up to 5 presence detectors and up to 5 SELV inputs. The product simplifies installation whilst providing an intelligent lighting control system. Provision is made for 4 volt-free power outputs rated for 415V isolation. Additionally, the unit features a switched output for Maintained Live to allow initiation of Emergency Lighting Test. The CDH4U5 has the ability to operate from dual supplies with the capability to modify its operating behaviour when failure is detected on one of the supplies. This feature is described in greater detail in application note AN4027.

*Note: Refer to Technical Data section to find out maximum allowable number of luminaires.

Fixing

The CDH4U5 should be mounted in an enclosure with a DIN-rail.



Consideration should be given to access for installation and maintenance when selecting the enclosure and location. The external enclosure DIN-rail should comply with EN 60715.

Electrical Connections

The connections to this equipment should be made only by a suitably qualified person and in accordance with the current wiring regulations. A means of disconnection must be incorporated in the fixed mains wiring to this box in accordance with the current wiring regulations.

All the connections should be routed ensuring adequate strain relief on the cable before termination to the unit's pluggable connectors.

CAUTION: DO NOT CONNECT MAINS TO THE MLS BUS OR DIMMING OUTPUTS.

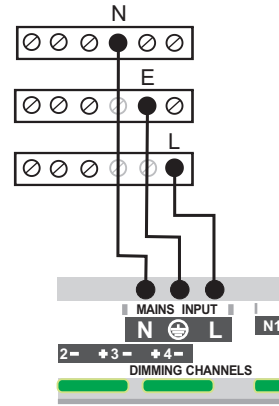

Connecting the Luminaires

Variants of the CDH4U5 are provided to control DSI, DALI and 1-10V ballasts. (See Part Numbers section for more details.)

Note: Dimming ballast types CANNOT BE MIXED on a single CDH4U5.

The CDH4U5 is equipped with 4 two-wire pluggable terminals for dimming outputs, 2 three-wire and 2 two-wire pluggable terminals for volt-free outputs.

The CDH4U5 has provision to connect more than one supply from different phases in three different scenarios: a) Single Supply, b) Essential and non-essential supplies and c) Two supplies equally likely to drop out.

a) Single Supply

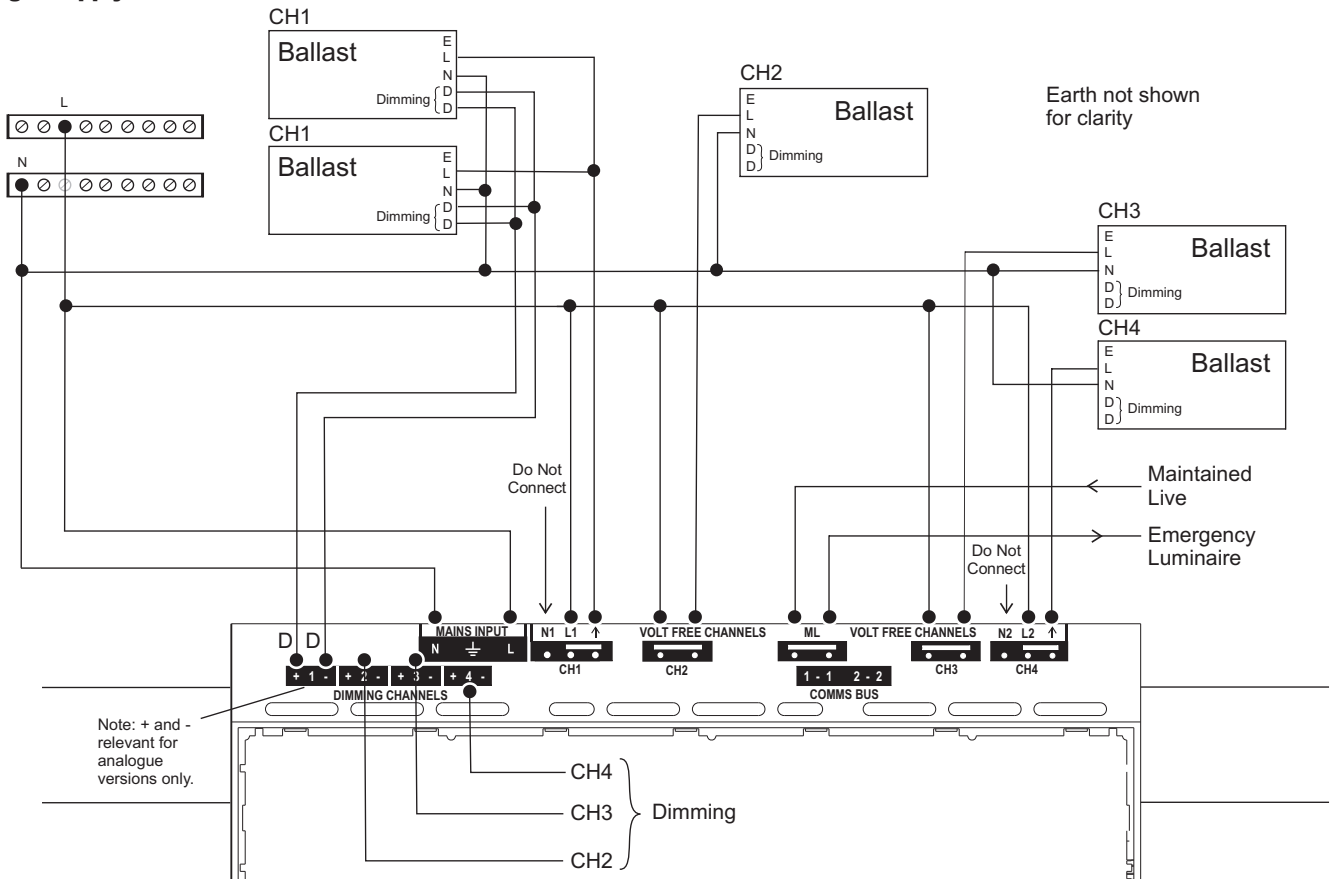

As shown above, the unit can be powered from a single supply; one or more luminaires may be connected to each channel.

b) Essential and Non-Essential Supplies

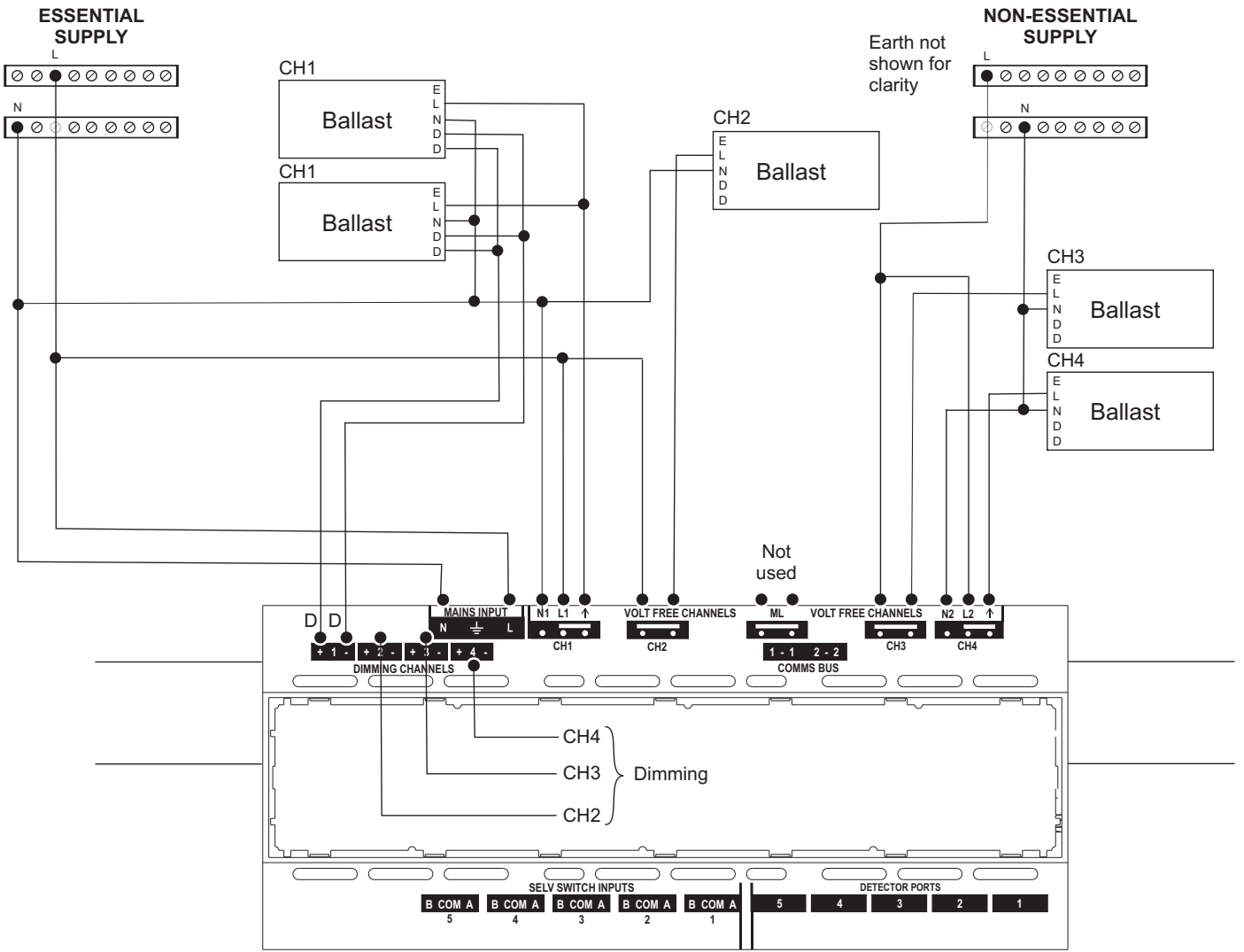

As shown in the above diagram, the unit may also be wired with two different supplies where one of the supplies is guaranteed to be available referred to as essential, while the other is referred as non-essential supply. The unit is recommended to be powered using the essential supply. As shown in the diagram, one or more channels may be powered from either of the supplies.

c) Two Supplies Equally Likely to Drop Out

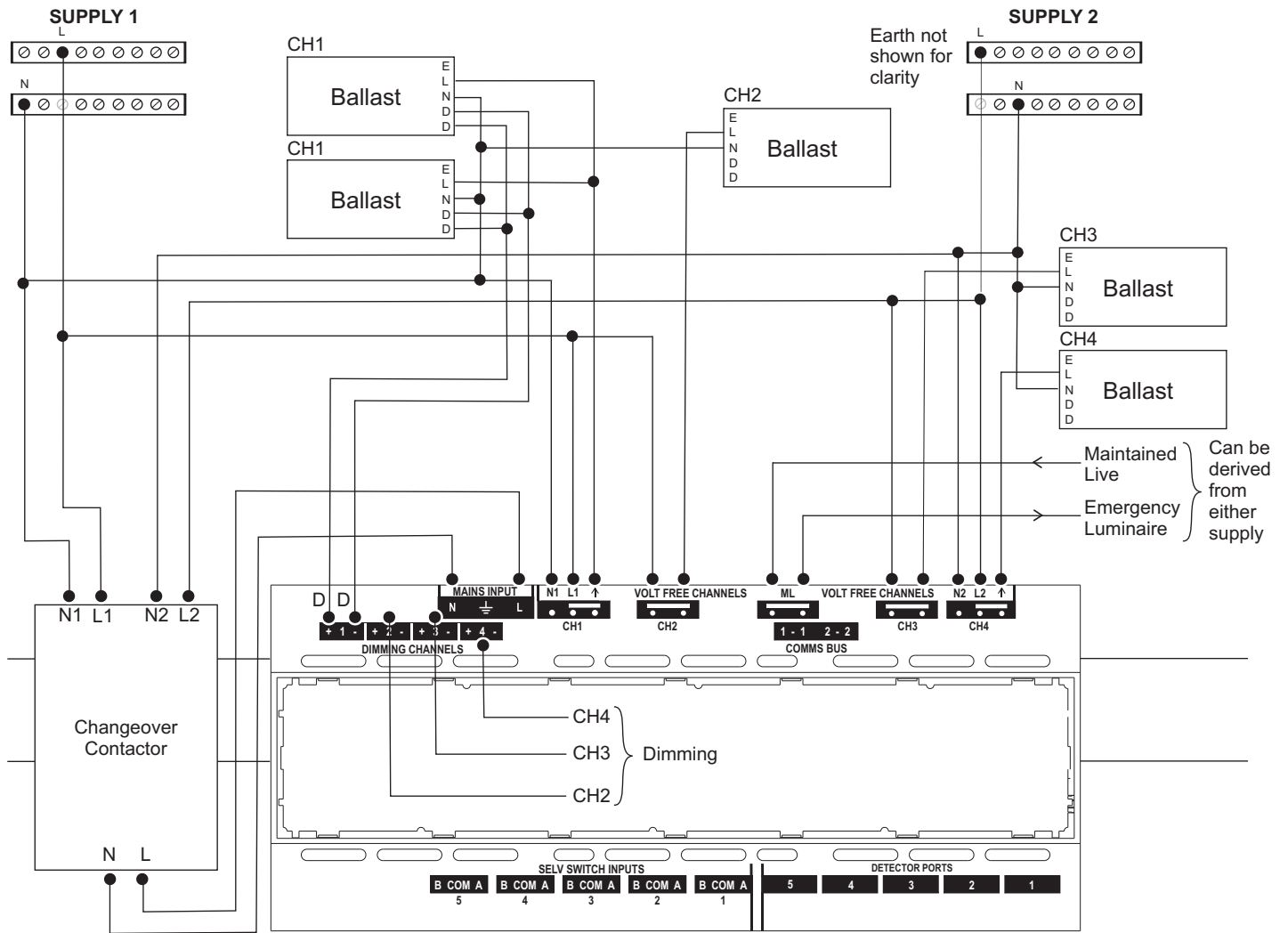

As shown in the diagram above, two equal supplies may be connected from a single phase or different phases. In order to maintain constant supply to the unit an external change-over contactor* is required. Line terminals from each of the supplies (N1, L1 and N2, L2) are connected via the change-over contactor. The Live and Neutral outputs from the contactor are connected to the mains input of the unit. In the case of failure of one of the supplies, the change-over contactor switches to the alternative supply to ensure continuous supply to the unit. As shown in the diagram above, one or more channels may be wired to run from either supply.

* Such as Lovato BG series mini-contactor.

Note: Please refer to AN4027 for recommendations on wiring supplies to the change-over contactor and part number.

Supply Failure Detection Mode

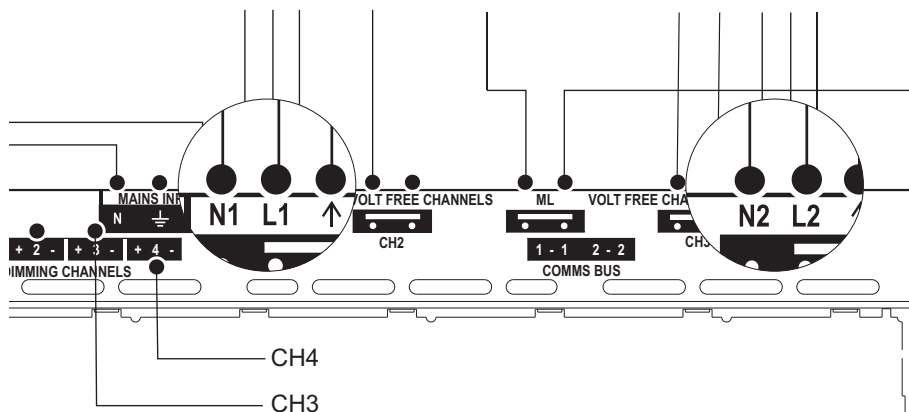

Channel 1 & Channel 4 are equipped with three-wire pluggable terminals with provision of connecting Neutral and Live from each supply. On detection of supply failure on Channels 1 or 4, the unit enters into special operating mode. During this mode, the unit controls the output of luminaires connected to the channel(s) fed by the remaining supply according to the settings of Scene 5. During this special operating mode, the unit will continue to respond to switch inputs and occupancy detection. The unit automatically reverts to normal behaviour once the failed supply has been restored.

Note: Please refer to the Commissioning section for programming the channel output settings of Scene 5.

Connecting Presence Detectors

The following SELV detectors are designed to interface to the CDH4U5:

MLS2500CDR Corner-mount Microwave presence detector with photocell, semi-flush mounted. Available with surface mount (SM suffix).

MLS2401CDR 360° Microwave presence detector with photocell, flush mounted. Available in surface mount version (SM suffix).

MLS2001CDR 360° PIR presence detector with photocell, flush mounted. Available in surface mount version (SM suffix).

MLSM2002CDR Controller for a 360° PIR detector with photocell. Used with the DHS OR DHW mini-head to form an integral luminaire-mounted unit.

Each connects to the CDH4U5 by means of an Ethernet-style RJ45 connector terminated patch lead which are available ready-made in 3m, 5m and 10m lengths. Up to five detectors may be connected to a CDH4U5.

Positioning Presence Detectors

For information on installing and positioning detectors, please refer to the installation instructions provided with the particular detector.

Connecting Switches

The CDH4U5 is equipped with SELV switch inputs which will typically be two way, centre off, momentary rockers, (e.g. the MK K4900 range). The logical function of a switch can be configured from a wide range of options and its action can be associated with any combination of channels. The switch connection consists of a 3-pole pluggable terminal block comprising a common and two returns from normally open contacts. Four plugs are provided with each CDH4U5, additional plugs can be ordered using the code CDHIP (5 pieces per pack).

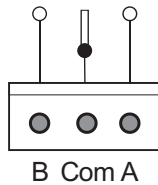

Note that if the SELV status of any one of the switches is compromised by reason of inadequate insulation or segregation of the cabling, then the SELV status of all other switches AND OF THE DETECTORS will also be compromised.

The recommended cable for use with the SELV switches is 3-core 300/500v 0.75mm² cable to CMA Reference 3183Y or for LS0H, to CMA Reference 3183B. The maximum allowable cable length between the switch mechanism and the CDH4U5 terminal block is 100m.

Three separate single wires should not be used.

Connecting the Communications Bus (MLS)

It is imperative that the MLS Bus be wired in the correct type of cable. Normally it should be 1.5mm² unscreened twisted pair. See Application Note AN4001. **Do not connect Mains to the MLS Bus.**

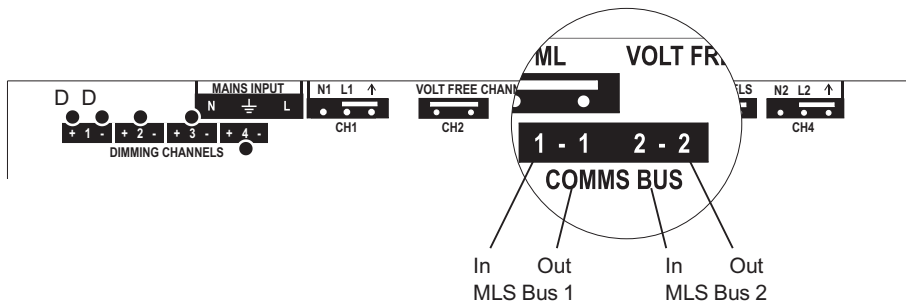

For connection of Bus Power Supply variants, see also Supplementary Installation Instructions W5071.

Commissioning

The LCM is commissioned using a dedicated programme running on a Windows-based computer. Commissioning settings may then be directly uploaded from the computer to the LCM or transferred to an HP2000 hand-held programmer for easy upload on site.

Communication from the PC can be by means of a USB infrared transceiver which can signal directly to the LCM's on-board infrared port over a short range or via any attached presence detector from beneath (range: 1-3m).

The main parameters for configuration are tabulated below. These parameters may be re-programmed any number of times and all settings will be retained in the event of a power loss.

PARAMETERS	OPTIONS
Per Box Parameters:	
Switch A: 1-5, Switch B: 1 -5, Switch 6A*, 6B*, 7A*, 7B*	User may choose any option for Switch A or Switch B from following: Sustain / Brighten / Dim / Off / Scene 01..06 / On / Partition / OneSwitch / On-Dim / Off-Brighten / On-Brighten / Off-Dim / Emergency Test / Emergency End (See separate table for detailed description of Switch Input options)
Detector 1-5: Range	Max 100%, Max 75%, Max 50% High 100%, High 75%, High 50% Med 100%, Med 75%, Med 50% Low 100%, Low 75%, Low 50% Min 100%, Min 75%
Per Channel Parameters:	
Ballast Type	Non-Dimming, 1% DSI, 3% DSI, 10% DSI, 1% DALI, 3% DALI, 10% DALI
Assigned Detectors	Detectors 1-5: Assigned or not assigned to this channel
Assigned Photocell	Photocell 1-5 (in Detectors 1-5): Assigned or not assigned to this channel
Assigned Switches	Switch A & B: Assigned or not assigned to this channel
Power Up	On / Off
Response	Auto, Manual/Bus, Manual only
Off Delay (Main Time Delay)	10 seconds to 96 hours / Disabled
Bus Connect	Yes / No
Zones 1-4	Zone number 1-100
Corridor 1-2: Begin	Zone number 1-100
Corridor 1-2: End	Zone number 1-100
Global 1-2 Rx	Yes / No
Manual I/P (Local/Share for Each Switch)	Obey locally only / Obey locally and transmit command on MLS bus
Start Lamps	Max / Min
Entry Scene	Scene 1-6
Lamp Max	100%, 90%, 80%, 70%, 50%, 45%, 40%, 35%, 30%, 25%, 20%, 15%, 10% Note: Not required for VF or SELV Outputs
When Vacant (Turn-Off Options)	Off until next occupancy detection Minimum, 25% or Scene 6 until next occupancy detection Minimum, 25% or Scene 6 for 3 x Off Delay Minimum, 25% or Scene 6 until the building is empty
Fade to Off	Yes / No
Bright Out	Yes / No
Photocell	Regulate (100%, 90%, 80%, 70%, 60%, 50%) / Passive / Active / Disabled Note: Not required for VF or SELV Outputs
Set-Point Low (Photocell Lower Threshold)	0-1024 (used in Regulating Scene 1) Note: Not required for VF or SELV Outputs
Set-Point High (Photocell Upper Threshold)	0-1024 (used in Regulating Scene 1) Note: Not required for VF or SELV Outputs
Scene 2	Output 0-100%
Scene 3	Output 0-100%
Scene 4	Output 0-100%
Scene 5	Output 0-100%
Scene 6	Output 0-100%
100 Hour Burn-in	Burn-in 100hrs/Cancel/Resume - See Application Note AN4028

* Planned

Description of Switch Input Options:

SELV Switch Options	Description
Sustain	Causes assigned channels to act as if an occupancy detector continues to detect occupancy
Brighten	Raises light level . Works only with dimmable ballasts.
Dim	Lowers Light level . Works only with dimmable ballasts.
Off	Turns lamp OFF
Scene 01..06	Recalls Scene assigned (any scene 01 to 06 as configured)
On	Turns lamp ON
Partition	Initiates logical partition of a room. Refer to AN4002 for more details
OneSwitch	Simple momentary push-to-make wallswitch that can be used to raise or lower the lighting level or toggle the output of the unit ON or OFF. Short press toggles output ON and OFF; long press will ramp the light level Up or Down.
On-Dim	Short Press will turn the output ON, long press will lower the light level
Off-Brighten	Short Press will turn the output OFF, long press will raise the light level
On-Brighten	Short Press will turn the output ON, long press will raise the light level
Off-Dim	Short Press will turn the output OFF, long press will lower the light level
Emergency Tst	Initiates manual test of emergency luminaire by turning OFF the Maintained Live
Emergency End	Restores Maintained Live to end the Emergency Test

Product Applications

The CDH4U5 may be used in various different applications, e.g. warehouse, school, hospital etc having a single supply or two different supplies. For more details on the differing applications, please refer to Application Note AN4027.

Connections

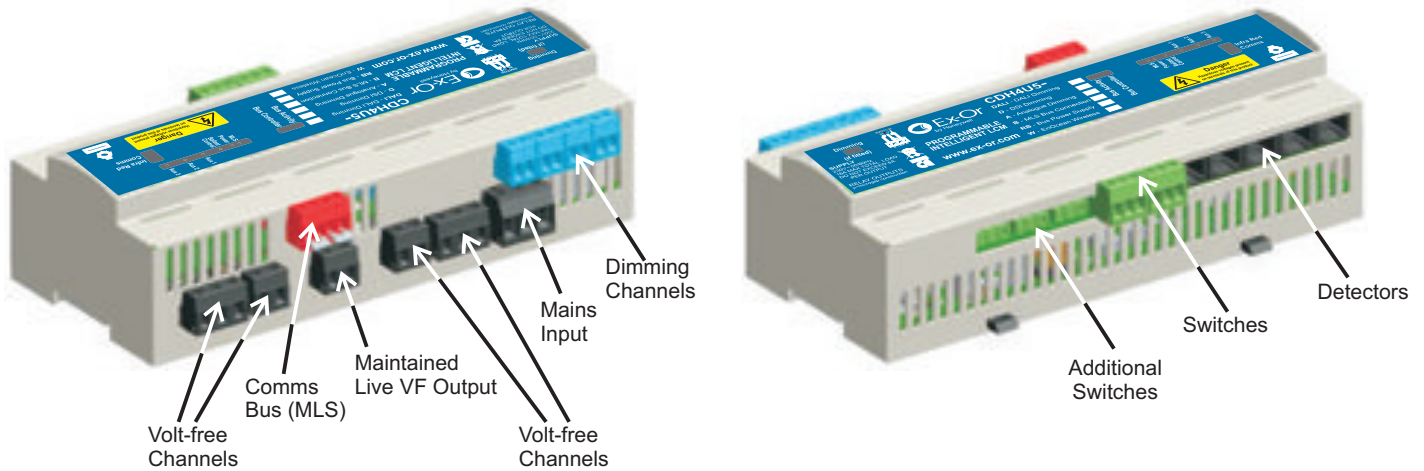

Technical Data

Operational supply:	230VAC ~50Hz/60Hz
Power consumption:	18W maximum
Product rating & recommended circuit protection:	16A or 20A MCB
Maximum load (per channel):	6A
Digital dimming ballasts per channel:	10 maximum
Digital dimming ballasts per LCM:	40 maximum
1-10V dimming ballasts per channel:	20mA (sinking only). See manufacturer's specification: worst case 10 Ballasts but Philips HF-R, for example, 20 Ballasts.
Maintained live output:	6A
Mains supply terminal capacity:	2x2.5mm ² or 1x4mm ²
Override switch input connector:	2.5mm ²
MLS bus connector:	2.5mm ²
MLS bus cable:	1.5mm ² unscreened twisted pair: see Application Note AN4001
Case material:	Self-extinguishing blend PC/ABS
Case finish:	Gray RAL 7035
IP rating:	20

Dimensions

Width (W) = 213 mm
 Height (H) = 62 mm
 Depth (D) = 91 mm
 Weight = 0.55kg approx

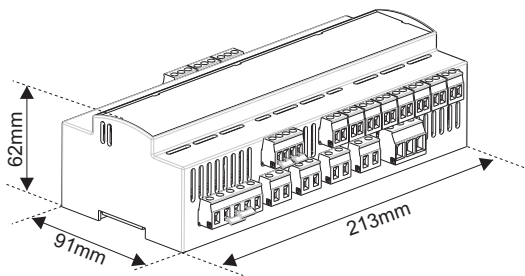

Enclosure

An enclosure (K5612S MAG) is available for this product. It provides integral connection bars fitted with link. It features a robust base together with an all-over front cover and moulded lid in an impact-resistant, flame-retardant thermoplastic. Cable entry points are located on top, bottom, side and rear surfaces.

Colour:	Magnolia
Dimensions:	306mm x 230mm x 110mm
Protection:	BS EN 60529 to IP2XC

Part Numbers

Programmable Intelligent Lighting Control Modules (LCM):

CDH4U5	4-Channel LCM
CDH4U5-A	4-Channel LCM - Analogue Dimming
CDH4U5-D	4-Channel LCM - DSI Dimming
CDH4U5-DALI	4-Channel LCM - DALI Dimming
CDH4U5-B	4-Channel LCM with MLS Bus
CDH4U5-BA	4-Channel LCM with MLS Bus - Analogue Dimming
CDH4U5-BD	4-Channel LCM with MLS Bus - DSI Dimming
CDH4U5-BDALI	4-Channel LCM with MLS Bus - DALI Dimming
CDH4U5-BAWL*	4-Channel LCM with MLS Bus, Wireless-switch enabled - Analogue Dimming
CDH4U5-BDWL*	4-Channel LCM with MLS Bus, Wireless-switch enabled - DSI Dimming
CDH4U5-BDALIWL*	4-Channel LCM with MLS Bus, Wireless-switch enabled - DALI Dimming
CDH4U5-RB	4-Channel LCM with MLS Bus Power Supply Unit
CDH4U5-RBA	4-Channel LCM with MLS Bus Power Supply Unit - Analogue Dimming
CDH4U5-RBD	4-Channel LCM with MLS Bus Power Supply Unit - DSI Dimming
CDH4U5-RBDALI	4-Channel LCM with MLS Bus Power Supply Unit - DALI Dimming
CDH4U5-RBAWL*	4-Channel LCM with MLS Bus Power Supply Unit, Wireless-switch enabled - Analogue Dimming
CDH4U5-RBDWL*	4-Channel LCM with MLS Bus Power Supply Unit, Wireless-switch enabled - DSI Dimming
CDH4U5-RBDALIWL*	4-Channel LCM with MLS Bus Power Supply Unit, Wireless-switch enabled - DALI Dimming

Plug-in Cards:

CDHDC	Plug-in Digital Dimming Card
CDHAC	Plug-in Analogue Dimming Card
CDHBC	Plug-in MLS Bus Interface
CDHRB	Plug-in MLS Bus Power Supply Unit
CDHWL*	Plug-in Wireless EnOcean Card

Presence Detectors with photocell:

MLS2500CDR	Corner-mount Microwave, semi-flush mounted
MLS2500CDRSM	Corner-mount Microwave, surface mounted
MLS2401CDR	360° Microwave, flush mounted
MLS2401CDRSM	360° Microwave, surface mounted
MLS2001CDR	360° PIR, flush mounted
MLS2001CDRSM	360° PIR, surface mounted
MLSM2002CDR	Control Module for integration within luminaire
DHS	360° PIR detector for use with MLSM2002CDR - silver bezel
DHW	360° PIR detector for use with MLSM2002CDR - white bezel
DHFK-S	Flush-mounting Kit for integral detector (DHS) - silver
DHFK-W	Flush-mounting Kit for integral detector (DHW) - white

Detector Patch Leads:

BT5E030GY	3m Patch Lead
BT5E050GY	5m Patch Lead
BT5E100GY	10m Patch Lead

Connectors:

CDHDOP	2-way Plug - blue - dimming outputs (2 pieces)
CDHSLOP	2-way Plug - black - switched live outputs (2 pieces)
CDHIP	3-way Plug - green - SELV switch inputs and auxiliary relay (5 pieces)
CDHBUSP	4-way Plug - red - MLS (1 piece)
CDHMIP	3-way Plug - black - mains input (1 piece)
CDH4VFP	3-way Plug - black - volt-free channels (2 pieces)

Ancillary Items:

UIRD1	USB Programming Dongle
RB2000	MLS Digital Bus Power Supply
RB2000LT	MLS Digital Bus Power Supply 'Lite'
K5612S MAG	Enclosure

* Planned - please contact Sales Department for latest information

Ex-Or

Novar ED&S Limited
Haydock Lane, Haydock, Merseyside WA11 9UJ
Tel: +44 (0)1942 719229 Fax: +44 (0)1942 508753
Email: technicalsales.ex-or@honeywell.com
www.ex-or.com

