

Installation Instructions

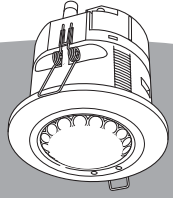

MLS Connect Digital PIR Sensor with photocell

⚠ Only suitably qualified personnel should install this equipment

50095812-001_Rev.B

Part Number	Flush Mount	Surface Mount	Fixed Housing	Tilt Housing	Office Type	Hi-Bay	Mid-Bay
MLS3000CDRF	•						
MLS3000CDRSM		•	•				
MLS3003CDRF	•						
MLS3003CDRSM		•	•				
MLS3003CDRHBF	•						
MLS3003CDRHBSM		•	•				
MLS3003CDRMBF	•						
MLS3003CDRMBSM		•	•				

360° Passive Infrared Sensor with Photocell for use with CDW12U5, CDH4U5 & CDH8U5 Programmable Intelligent Lighting Control Modules
(HC5A, HP2000 or QuickSet Pro required for Photocell Commissioning)

Installing the Sensor into Ceiling Tile

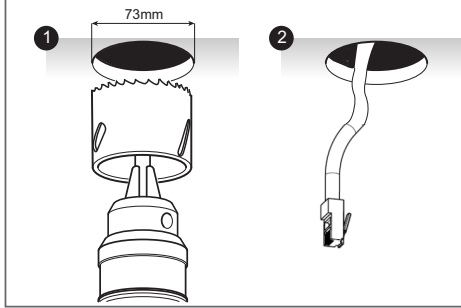

Removing the Terminal Cover

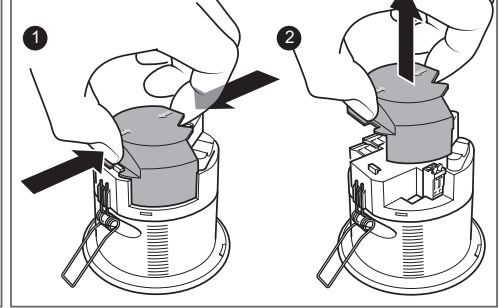

Fixing to Ceiling - Standard Method

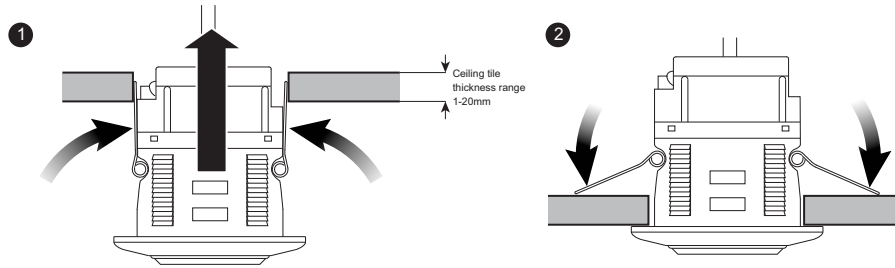

Fixing to Ceiling - Secure Lockring Method (Available separately, please order LOCKRING)

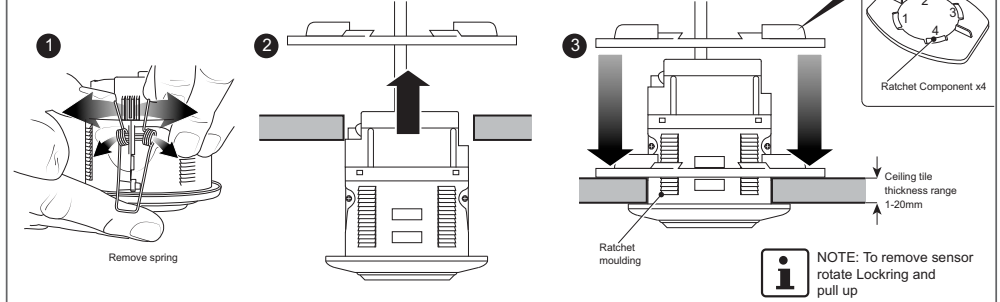

Electrical Connections

Introduction

The MLS3000CDR & MLS3003CDR offer high performance presence detection and contain a photocell to monitor total light levels, allowing the light output of dimmable luminaires to be adjusted to suit the natural light level available. An integrated infrared port can be used both for local control from a hand-held device, when in service, and for initial CDW12U5/CDH4U5/CDH8U5 system commissioning. When properly installed and connected the MLS3000CDR & MLS3003CDR are SELV devices.

Connecting

The MLS3000CDR & MLS3003CDR connect to the LCM via an eight core, RJ45 plug terminated, patch lead see fig1. **All such patch leads must be segregated from mains wiring to preserve the detectors SELV status that is provided by the LCM design.**

Ready-made patch leads in lengths of 3m, 5m and 10m are available from Ex-Or. (See overleaf for Part Numbers.)

Where it is a requirement that the patch leads are protected by conduit it may prove more convenient to run the cables unterminated and attach the RJ45 connectors afterwards. In this case the cable used should be 4-twisted pair, 24awg multi-stranded, unshielded data cable to Category 5E standard (e.g. Belden Datatwist 350). No strain-relief hoods should be fitted to the insulation displacement RJ45 connectors, due to the limited space available above the emplaced detector. **Note that the maximum allowable cable length between the MLS3000CDR & MLS3003CDR and the CDW12U5 Connection Box is 100m.**

The wiring scheme used should follow either the T-568A or the T-568B Ethernet standards, and must give "1-1", "straight-through" connectivity between the two RJ45 connectors for all eight cores. **Note that this detector is not an Ethernet device and cannot be used with network Hubs and Switches.**

Plug the RJ45 connector at the detector station into the modular socket labelled "To CD Box" on the top of the detector module and offer the detector to the backbox.

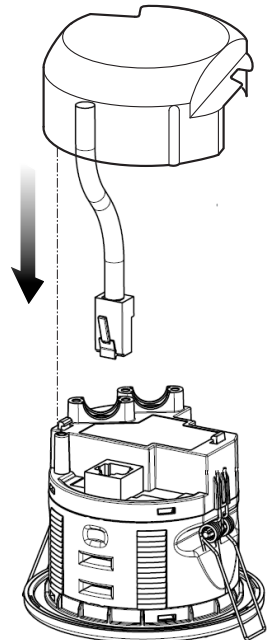

fig 1

Commissioning

In the CDW12U5 and CDH4U5/CDH8U5 systems, all configuration information is held within the Lighting Control Modules themselves, not in individual detectors. Most of the configuration items are set up with the aid of a dedicated programme running on a portable PC which communicates with the LCM either by an infrared link via one of the attached detectors, or by a specialised serial link into the LCM itself. However, when setting the actual light levels around which dimming or switching decisions are to be made, the system allows the commissioning engineer the same convenience as if he were dealing with traditional stand-alone detectors. An infrared programming tool, the HP2000, QuickSet Pro or HC5A is used to set the controlling or switching setpoint for the photocell. In all cases the setting is then transmitted from the detector to the LCM, where it is uniquely associated with the detector number being dealt with and will be preserved in the event of power failure. All settings can be re-programmed any number of times.

Setting the Regulating Photocell

Using the HP2000 or QuickSet Pro Programmer, enter the Utilities menu and select 'Set Light Level'. Use the 'up' and 'down' buttons to manually adjust the light output from the luminaire(s) and when at the required level press and hold 'OK' to store. The luminaire(s) will blink to acknowledge a successful store operation.

Due to the fact that the photocell is on the ceiling looking down, it is not possible for measurements made with a lux meter on the working plane to remain constant when daylight illuminates the ceiling and the working plane to a differing extent. Therefore, products of this type should be regarded as capable of maintaining an APPROXIMATE light level only.

Setting the Switching Photocell

Now the desired switching light level must be arrived at either by waiting for an appropriate time of day or by a combination of manually switching off lights and perhaps masking windows. Using the HP2000 or QuickSet Pro Programmer, enter the Utilities menu and select 'User Remote'. Scroll down to 'Scene 1' and press and hold the 'OK' button to store. The luminaire(s) will blink to acknowledge a successful store operation.

Testing

Detectors can be put into a temporary 10 second Off-delay mode to speed the process of checking their sensitivity and range settings using the HP2000 or QuickSet Pro Utilities menu Walk Test option. This mode expires automatically after a few minutes.

Fixing to Ceiling – Surface Mounting (optional)

Product variants with "SM" suffix on the part number are supplied with the surface fitting kit as standard. The surface mount kit is available as a separate part, please order SURFMT.

The sensor may be mounted to any suitable surface, but is most commonly fixed to a conduit stop-end (fig 2 set) (BESA) box or bushed to trunking.

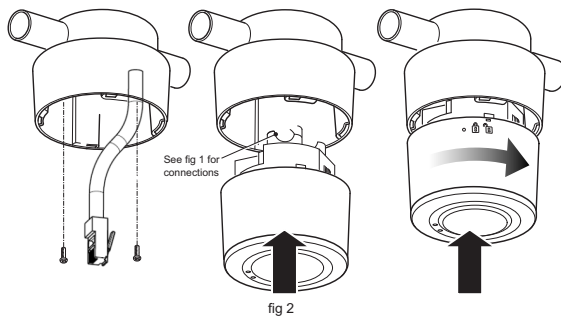

See fig 1 for connections

fig 2

Uninstalling and Repositioning

Insert a flat headed screwdriver into the slot as shown and twist the collar anti-clockwise to release, (fig 3).

To separate the sensor from the surface mount casing, push a flat headed screwdriver onto the tab via the inside void of the casing and pull the sensor upwards, (fig 4).

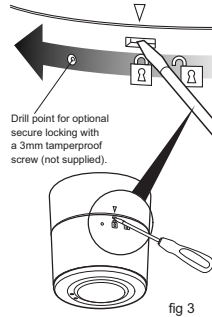

Drill point for optional secure locking with a 3mm tamperproof screw (not supplied).

fig 3

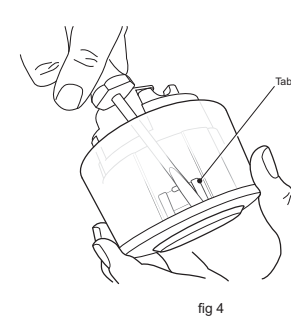
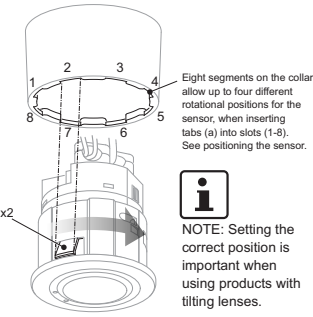

fig 4



Eight segments on the collar allow up to four different rotational positions for the sensor, when inserting tabs (a) into slots (1-8). See positioning the sensor.

i NOTE: Setting the correct position is important when using products with tilting lenses.

Tilt and Lock the Sensor

Some products feature the ability to tilt the sensor (before fitting) by up to 10° in 2° increments, in order to extend the range in one direction. This may be useful in cases where the ideal mounting location is not available. The increased range is indicated in fig 5.

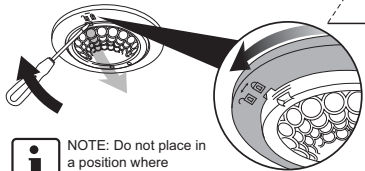

fig 5

Type	Radius extension at full tilt
Office	up to 67%
Mid-Bay	up to 43%
Hi-Bay	up to 42%

Positioning the Sensor

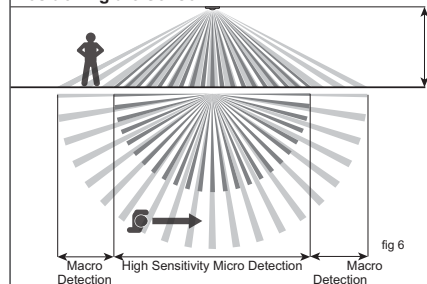

fig 6

The sensor should be positioned on the ceiling in the centre of the occupied space. This product is available in three different mounting height variants; see fig. 1 and the table below. Ensure that the maximum recommended mounting height is not exceeded. Do not mount within 0.25m of a luminaire.

Avoid mounting next to an AC unit.

For additional information on positioning please refer to 'Tilt and Lock the Sensor'.

i The sensor is more sensitive to movement across the beam compared with movement towards the centre.

Type	Aspect Ratio (diameter : height)		Max Recommended Mounting Height
	Micro Detection - High Sensitivity	Macro Detection - Standard Sensitivity	
Office (7m diameter @ 2.5m height)	2.8:1	4:1 (10m diameter @ 2.5m height)	3.5m
Mid-Bay	N/A	2:1 (20m diameter @ 10m height)	12m
Hi-Bay	N/A	1.9:1 (27m diameter @ 14m height)	16m

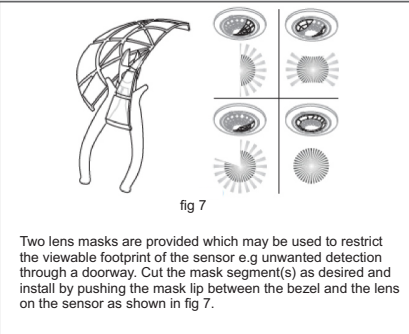

fig 7

Two lens masks are provided which may be used to restrict the viewable footprint of the sensor e.g unwanted detection through a doorway. Cut the mask segment(s) as desired and install by pushing the mask lip between the bezel and the lens on the sensor as shown in fig 7.

Technical Data

OPERATING VOLTAGE: 12V DC, SELV if installed correctly.
 PHOTOCELL: Regulating
 WEIGHT: 106g - MLS3000CDR
 117g - MLS3003CDR
 COLOUR: White RAL9010
 MATERIAL: Flame retardant PC/ABS
 IP RATING: 4X

Part Numbers

BT5E030GY 3m Detector Patch Lead
 BT5E050GY 5m Detector Patch Lead
 BT5E100GY 10m Detector Patch Lead
 SURFMT Surface-mount Kit (supplied with SM versions)
 LOCKRING Secure Lockring

TECHNICAL SUPPORT
tech@ecs.net.au



At the end of their useful life the packaging and product should be disposed of via a suitable recycling centre. Do not dispose of with normal household waste. Do not burn.



Energy Conservation Solutions Pty Ltd - Exclusive Distributor - Australian and New Zealand
 Locations: VIC/TAS, NSW, QLD, FNQ, ACT, SA/NT, WA, NZ. For Contact Details Visit: www.ecs.net.au



W5102C