

Vemer S.p.A.

I - 32032 Feltre (BL) • Via Camp Lonc, 16
Tel +39 0439 80638 • Fax +39 0439 80619

e-mail: info@vemer.it - web site: www.vemer.it

Mod. NAPA



USER MANUAL

ELECTROMECHANICAL TIME SWITCH WITH TRIPPERS

Read carefully all instructions

- The **NAPA** time switches are devices to control any electrical load by means of daily (NAPA-D, NAPA-RD, NAPA-ED) or weekly (NAPA-W, NAPA-RW) programs. They are designed for household and similar operation with normal pollution levels.

SAFETY WARNINGS

- The device must be installed and activated by qualified personnel, following the connection diagrams provided in this manual scrupulously
- After installation, it must be made impossible to access the terminals without specific tools
- Before accessing the connection terminals, verify that the leads are not live
- Do not connect or power the device if any part of it is damaged
- The device must be installed and activated in compliance with current electric systems standards
- Do not use the device for purposes other than those indicated.

Code	Model	Description
VP884100	NAPA-D	Electromechanical time switch with trippers - daily
VE049300	NAPA-ED	Electromechanical time switch with trippers - daily
VP886600	NAPA-RD	Electromechanical time switch with trippers - daily
VP885800	NAPA-W	Electromechanical time switch with trippers - weekly
VP887400	NAPA-RW	Electromechanical time switch with trippers - weekly

TECHNICAL CHARACTERISTICS

- Power supply: 230 V~ 50/60 Hz
- Power consumption: 1.8 W
- Contacts capacity: 0.5 W
- Actions type: 1B
- Operating accuracy: ± 1 second/day at 23°C
- Type of dial:
 - NAPA-D, NAPA-RD, NAPA-ED: 96 trippers
 - NAPA-W, NAPA-RW: 84 trippers
- Minimum time of functioning:
 - NAPA-D, NAPA-RD, NAPA-ED: 15 minutes
 - NAPA-W, NAPA-RW: 2 hours (120 minutes)
- Switching accuracy:
 - NAPA-D, NAPA-RD, NAPA-ED: 5 minutes
 - NAPA-W, NAPA-RW: 30 minutes
- Manual control by 3 positions selector:
 - Permanent disconnected (the set programming will be ignored)
 - Automatic operation
 - Permanent connected (the set programming will be ignored)
- Power reserve: 100 hours after an uninterrupted 48 hours power (not available on the NAPA-ED)
- Operating temperature: $-10^{\circ}\text{C} \div +45^{\circ}\text{C}$
- Protection class: II
- Protection category: IP20
- Installation:
 - NAPA-RD, NAPA-RW: panel
 - NAPA-D, NAPA-ED, NAPA-W: panel, DIN-rail or wall

PROGRAMMING

- Remove the transparent protection cover on the front of the time switch.
- The possible operating modes are selectable through the manual control on the front:
 - Permanently closed circuit (terminals contact 3-2 in ON).
 - Automatic operation.
 - permanently open circuit (terminals contact 3-2 OFF).
- For automatic operation of the inserter, position the selector in correspondence of the symbol .
- Move upward all trippers of the external dial.
- Program the clock intervention by moving down the trippers in correspondence of the desired intervention time. The number of the trippers downward, determines the duration of stay in ON position of the contact between terminals 3 and 2. Each tripper corresponds to 15 minutes (NAPA-D, NAPA-RD, NAPA-ED) or 2 hours (NAPA-W, NAPA-RW) of functioning.
- Set the current time and minutes by acting directly on the external dial, turning it clockwise.
- Place the transparent protection cover in its casing
- Give power to the time switch.

REFERENCE STANDARDS

Compliance with Community Directives

2014/35/UE (LVD)**2014/30/UE** (EMCD)

is declared in reference to the harmonized standard:

• **EN 60730-2-7**

DIMENSIONS

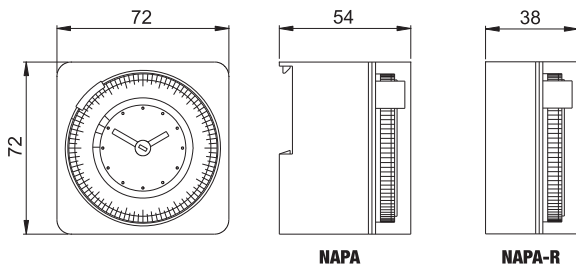

CONNECTION DIAGRAM

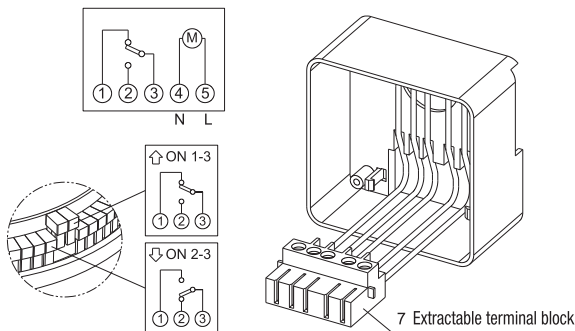

Incandescent		3000 W	Low consumption (CFL)		1000 VA
Fluorescent (neon)		1200 VA	Low consumption (CFL)		900 VA
Low voltage halogen		2000 VA	Led		200 VA
Halogen 230 V~		3000 W			

DESCRIPTION

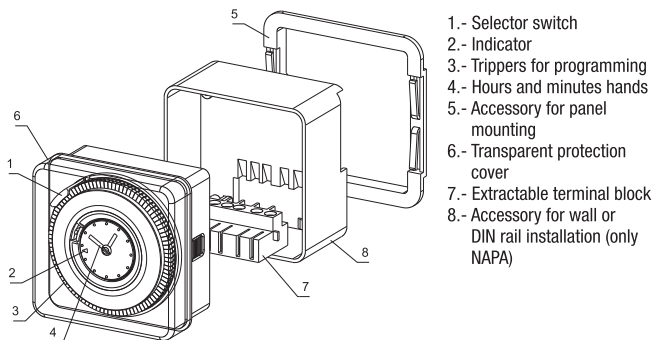

DIME HOLE

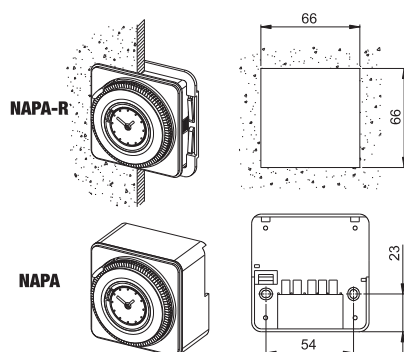

Energy Conservation Solutions Pty Ltd

Exclusive Distributor for **VEMER** in Australia
Locations: VIC/TAS, NSW, QLD, ACT, SA/NT & WA

Phone: **1300 306 136**

For contact details visit: www.ecs.net.au