



Mod. **ELO-D**
Mod. **ELO-W**

Vemer S.p.A.

I - 32032 Feltre (BL) • Via Camp Lonc, 16
Tel +39 0439 80638 • Fax +39 0439 80619
e-mail: info@vemer.it - web site: www.vemer.it



User Manual

ANALOG TIME SWITCH WITH TRIPPERS

Read all the instructions carefully

■ The **ELO-D** and **ELO-W** time switches control any electrical installation by means of daily (Elo-D) or weekly (Elo-W) programs. The cover on the side of the instrument makes it possible to replace the battery when it is run down. They are designed for household and similar operation with normal pollution levels.

SAFETY WARNINGS

- 1) The instrument must be installed and activated by qualified personnel, following the connection diagrams provided in this manual scrupulously.
- 2) After installation, it must be made impossible to access the terminals without specific tools
- 3) Before accessing the connection terminals, verify that the leads are not live
- 4) Do not connect or power the instrument if any part of it is damaged
- 5) The instrument must be installed and activated in compliance with current electric systems standards.
- 6) Do not use the instrument for purposes other than those indicated.

Code	Model	Description
VP877500	ELO-D	Daily analog time switch
VP878300	ELO-W	Weekly analog time switch

TECHNICAL SPECIFICATIONS

- Power supply: 230 V~ 50/60 Hz
- Power consumption: 0.5 W
- Switching capability: 16 (4) A 250 V~
- Operating accuracy: ± 1 second/day at 22°C
- Type of dial:
 - ELO-D: 96 pins
 - ELO-W: 84 pins
- Minimum time of functioning:
 - ELO-D: 15 minutes
 - ELO-W: 2 hours
- Switching accuracy:
 - ELO-D: ± 5 minutes
 - ELO-W: ± 30 minutes
- Manual control by 3 positions selector:
 - - Permanent disconnected
 - ⊕ - Automatic operation
 - I - Permanent connected
- Power reserve: 150 hours (NiMH rechargeable battery – replacing)
- Operating temperature: -10 °C ÷ +50 °C
- Protection class: II
- Protection category: IP20
- 1 DIN module container

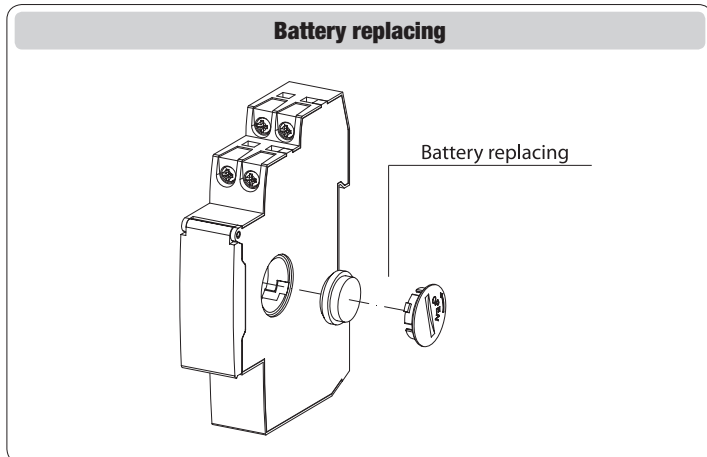
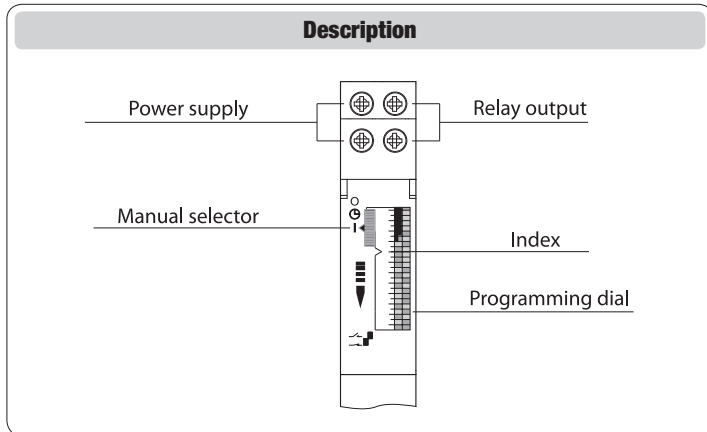
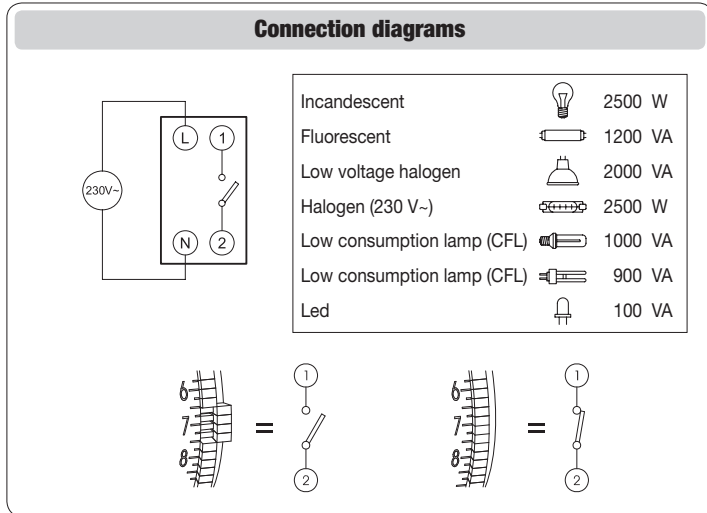
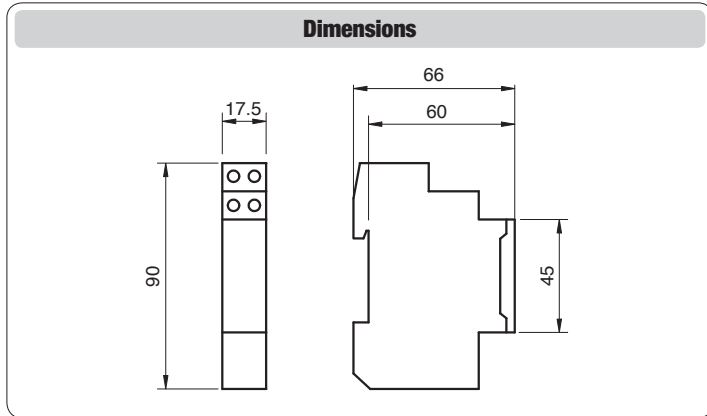

PROGRAMMING

- Take over all the pins to the right. Take over to the left the pins corresponding to the desired times of connection, in which the contact 1-2 will be closed.

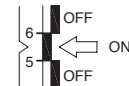

- Hour updating: Turn the dial until the index is on the current time.
- Set the operations mode by the manual selector.
- Connect the power supply

BATTERY REPLACING

- To replace the battery:
 - disconnect the power supply
 - remove the battery cover on the right side, turning in the direction of the arrow
 - replace the battery and replace the cover
 - connect the power supply
- Use V80H batteries only.
- Throw away the run down batteries in compliance with current regulations on the disposal of harmful waste.



REFERENCE STANDARDS

- Compliance with Community Directives
 - 2006/95/EC** (low voltage)
 - 2004/108/EC** (E.M.C.)
 is declared in reference to the harmonized standard:
 - **EN 60730-2-7**

Energy Conservation Solutions Pty Ltd

Exclusive Distributor for **VEMER** in Australia
Locations: VIC/TAS, NSW, QLD, ACT, SA/NT & WA

Phone: **1300 306 136**

For contact details visit: www.ecs.net.au