

## DATA SHEET

### AOL 100 LED 5K

#### Order description

AOL 100 LED 5K white

#### Item number

EL10750007

#### GTIN

4015120750007

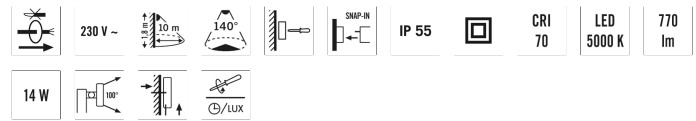

#### Product description

- Automatic light with built-in motion detector
- Design lamp made of die-cast aluminium and plastic
- 14 W, light colour approx. 5000 K white
- 140° field of detection, range up to 10 m at an installation height of 1.8 m

#### Technical data

GENERAL	
Conformity	CE, RoHS, WEEE
warranty	3-year
MOUNTING	
Installation type	Surface mounting
Mounting location	Wall
HOUSING	
Dimensions	Length 143 mm x Width 104 mm x Height/Depth 205 mm
Weight	570 g
Material	Aluminium and UV-stabilised plastic
Protection type	IP 55
Permissible ambient temperature	-25 °C...+50 °C
Colour	white, similar to RAL 9016
Terminal	2,5 mm <sup>2</sup> / 1,5 mm <sup>2</sup>
Glow wire test in accordance with IEC 60695-2-10	650 °C - 30 s
ELECTRICAL VERSION	
Protection class	II

Nominal voltage	230 - 230 V / 50 Hz
Stand-by consumption	0.5 W
LIGHT	
Diffusor	opal
Light emission	direkt
Beam angle	90 °
Flicker factor	<10 %
Rated output	14 W
Luminous Flux (light)	770 lm
Luminous efficacy	55 lm/W
LED service life	L80B10 = 50.000 h
Colour temperature	5000 K
Colour rendering index Ra	> 70
Energy efficiency class	A++ to A
SENSORS	
Detection angle	140°
Detection range diagonally	10 m
Field of detection	31 m <sup>2</sup>
Recommended installation height	1,8 m

## DATA SHEET

### AOL 100 LED 5K

Order description	Item number	GTIN
AOL 100 LED 5K white	EL10750007	4015120750007

#### Scale drawing

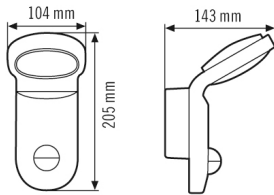

#### Field of detection

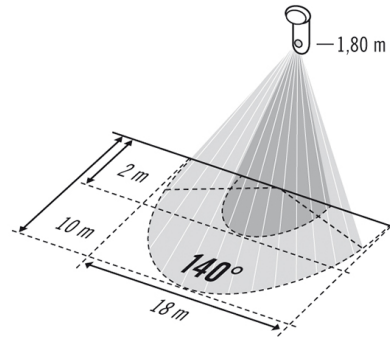

- Head-on to detector
- Passage area / diagonally to detector

#### Light distribution

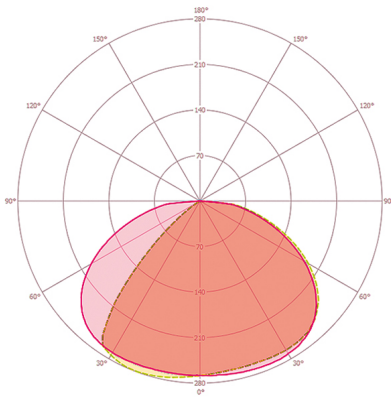

#### Circuit diagram

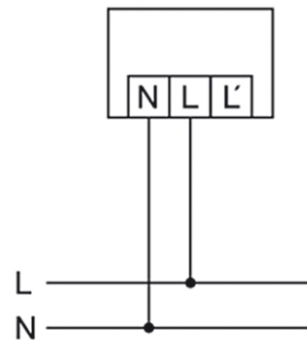

Standard operation

#### Circuit diagram

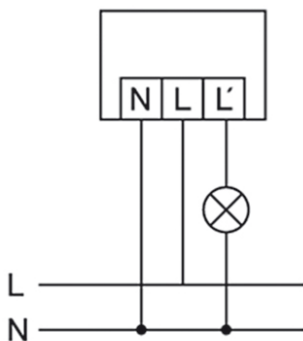

Standard operation with additional connection of external loads

**Energy Conservation Solutions Pty Ltd**

Exclusive Distributor for ESYLUX in Australia Locations:

VIC/TAS, NSW, QLD, ACT, SA/NT & WA

Phone: 1300 306 136

For contact details visit: [www.ecs.net.au](http://www.ecs.net.au)