



MEGALIT II

462 W Harbour and Outdoor
LED Area Lighting Luminaire

Order Code : 3112352
Product Code : MGL 462Z 50CM00 18 LLLL



Product Data

Standard Features

Housing	: Corrosion resistant, electrostatic powder coated compressed die-cast aluminium housing
Diffuser	: Tempered Glass
Angle	: 18° lens
IP Grade	: IP66
Installation	: Floor Mounted
Light Source	: Power LED

Optical & Electrical Features

Power Consumption	: 462 W
Final Luminous Flux	: 48300 lm
Efficacy	: 104.5 lm/W
Input Voltage	: 220-240 V AC
Frequency	: 50-60 Hz
Power Factor	: > 0,9
Surge Transient Protection	: 2 kV
Drive Current	: 741.6mA
Correlated Color Temperature	: 5000K
Color Rendering Index	: >70

Other Features & Conditions

Operating Temperature Range	: -20 °C/+50 °C
Impact Resistance	: IK08
Led Life Time - L70	: > 50.000 hours @Ta= 50 °C

Photometric Curve

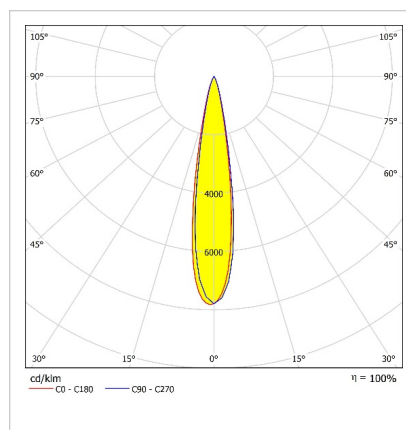

Optional Features

Angle Options : 12°, 30°, 60°

MEGALIT II

462 W Harbour and Outdoor LED Area Lighting Luminaire

3112352 MGL 462Z 50CM00 18 LLLL

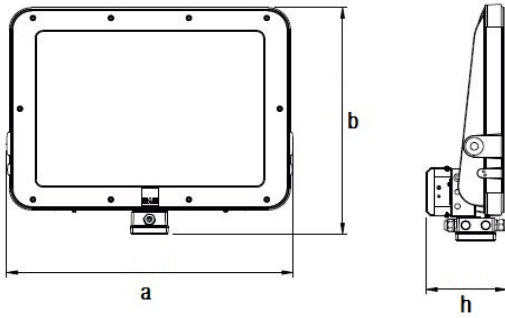

Dimensions (mm)

	a	b	h
Standard	691	492	178



Weight (kg)

Standard	24
----------	----

Energy Conservation Solutions Pty Ltd
Exclusive Distributor for EAE Lighting in Australia
Locations: VIC/TAS, NSW, QLD, ACT, SA/NT & WA
Phone: 1300 306 136
For contact details visit: www.ecs.net.au