

DATA SHEET

PNL 625 UMF FM WH

Order description	Item number	GTIN
PNLNOV11 ceiling flush mounting hou	EQ10113093	4015120113093

Product description

Ceiling flush mounting 625 for panel lights in the NOVA and CELINE ranges.



Technical data

MOUNTING

Installation type	Surface mounting
Installation position	Ceiling
Installation dimension	Installation length 644 mm x Installation width 644 mm x Installation depth 48,2 mm

HOUSING

Dimensions	length 660,4 mm x width 660,4 mm x Height/Depth 48,2 mm
Weight	1250 g
Housing material	painted aluminium
Colour	white, similar to RAL 9003

Scale drawing

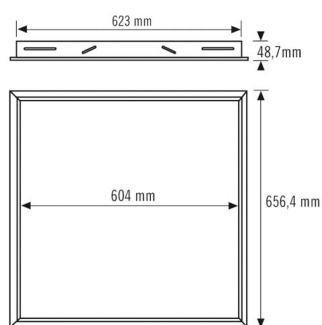

Energy Conservation Solutions Pty Ltd

Exclusive Distributor for ESYLUX in Australia Locations:

VIC/TAS, NSW, QLD, ACT, SA/NT & WA

Phone: **1300 306 136**

For contact details visit: www.ecs.net.au